

4c O 42/20



Pronounced on 21 December 2021  
XXX

**Düsseldorf District Court  
IN THE NAME OF THE PEOPLE**

**Judgment**

In the civil case

of **XXX**

Plaintiff,

Legal Representatives:

XXX

against

the **XXX**

Defendant,

Attorney of record:

XXX

Intervenor of the Defendant:

**XXX**

Attorney of record

XXX

the 4c. Civil Chamber of Düsseldorf District Court at the oral proceedings on  
October 21, 2021

XXX

**ruled:**

- I. The Defendant is ordered to provide the Plaintiff in a separate list, if available also in electronic form - with regard to the statements a) and b) under presentation of invoices, alternatively delivery bills, further alternatively receipts in copy, whereby data, to which the owed information and accounting does not refer and with regard to which a justified interest in secrecy of the Defendant exists, may be covered or blacked out - with information about the extent to which it has since January 28, 2017

offered, placed on the market, used or either imported or possessed for the aforementioned purposes in the Federal Republic of Germany;

1. A decoder for reconstructing a picture from a datastream into which the picture is coded in units of slices into which the picture is partitioned, wherein the decoder is configured to decode the slices from the data stream in accordance with a slice order and the decoder is responsive to a syntax element portion within a current slice of the slices, so as to decode the current slice in accordance with one of at least two modes, and

in accordance with a first of the at least two modes, decode the current slice from the datastream using context adaptive entropy decoding including derivation of contexts across slice boundaries, a continuous update symbol probabilities of the contexts and initializing symbol probabilities depending on stored states of symbol probabilities of a previously decoded slice, and predictive decoding across the slice boundaries from the data stream; and

in accordance with a first of the at least two modes, decode the current slice from the datastream using context adaptive entropy decoding with restricting the derivation of the contexts so as to not cross the slice boundaries, a continuous update of symbol probabilities of the contexts and an initializing the symbol probabilities independently of any previously decoded slice, and predictive decoding with restricting the predictive decoding so as to not cross the slice boundaries; and

wherein the picture is partitioned into coding blocks arranged in rows and columns and having a raster scan order defined among each other, and the decoder is configured to associate each slice with a continuous

subset of the coding blocks in the raster scan order so that the subsets follow each other along the raster scan order in accordance with the slice order, and

wherein the decoder is configured to save symbol probabilities as obtained in a context adaptive entropy decoding of the previously decoded slice up to a second coding block in a row in accordance with the raster scan order, and, upon initializing the symbol probabilities for the context-adaptive entropy decoding of the current slice in accordance with the first mode, check as to whether a first coding block of the continuous subset of coding blocks associated with the current slice is a first coding block in a row in accordance with the raster scan order, and, if so, initialize the symbol probabilities for the context adaptive entropy decoding of the current slice depending on the saved symbol probabilities as obtained in context adaptive entropy decoding the previously decoded slice up to a second coding block in a row in accordance with the raster scan order, and, if not, initialize the symbol probabilities for the context adaptive entropy decoding of the current slice depending on symbol probabilities as obtained in context adaptive entropy decoding the previously decoded slice up to the end of the previously decoded slice.

2. To offer or supply for use in the Federal Republic of Germany to third parties in the Federal Republic of Germany:

Means for performing a method for reconstructing a picture from a datastream into which the picture is coded in units of slices into which the picture is partitioned, wherein the method comprises decoding the slices from the datastream in accordance with a slice order and the method being responsive to a syntax element portion within a current slice of the slices, so as to decode the current slice in accordance with one of at least two modes, wherein

in accordance with a first of the at least two modes, the current slice is decoded from the datastream using context adaptive entropy decoding including a derivation of contexts across slice boundaries, a continuous update of symbol probabilities of the contexts and initializing of the symbol probabilities depending on saved states of symbol probabilities of a

decoded slice, and predictive decoding across the slice boundaries, and in accordance with a second of the at least two modes, the current slice is decoded from the datastream using context adaptive entropy decoding with restricting the derivation of the contexts so as to not cross the slice boundaries, a continuous update of symbol probabilities of the contexts and an initialization of the symbol probabilities independent of any previously decoded slice, and predictive decoding with restricting the predictive decoding so as to not cross the slice boundaries,

wherein the picture is partitioned in coding blocks arranged in rows and columns and having a raster scan order defined among each other, and the method comprises associating each slice to a continuous subset of the coding blocks in the raster scan order so that the subsets follow each other along the raster scan order in accordance with the slice order, and wherein the method comprises saving symbol probabilities as obtained in context adaptive entropy decoding of the previously decoded slice up to a second coding block in a row in accordance with the raster scan order and, in initializing the symbol probabilities for context adaptive entropy decoding of the current slice in accordance with the first mode, checking as to whether a first coding block of the continuous subset of coding blocks associated with the current slice is a first coding block in a row in accordance with the raster scan order, and, if so, initializing the symbol probabilities for the context adaptive entropy decoding of the current slice depending on the saved symbol probabilities as obtained in context adaptive entropy decoding the previously decoded slice up to a second coding block in a row in accordance with the raster scan order, and, if not, initializing the symbol probabilities for the context adaptive entropy decoding of the current slice depending on symbol probabilities as obtained in context adaptive entropy decoding the previously decoded slice up to the end of the previously decoded slice,

and namely by specifying

- a) the quantity of products received or ordered and the names and addresses of manufacturers, suppliers and other previous owners,
- b) of the individual deliveries, broken down by delivery quantities, times and prices, the respective type designations and the names and addresses of the customers,
- c) of the individual offers, broken down by offer quantities, times and prices, the respective type designations and the names and addresses of the recipients of the offers,
- d) the advertising carried out, broken down by advertising medium, its circulation volume, distribution period and distribution area, and in the case of Internet advertising, the domain, access figures and placement periods, and

whereby the Defendant reserves the right to disclose the names and addresses of the non-commercial customers and offerees instead of the Plaintiff to a certified public accountant domiciled in the Federal Republic of Germany to be designated by the Defendant and bound to secrecy vis-à-vis the Plaintiff, provided that the Defendant bears the costs thereof and authorizes and obligates him to inform the Plaintiff upon specific request whether a certain customer or offeree is included in the list.

- II. It is hereby determined that the Defendant is obligated to compensate the Plaintiff for all damages that the Plaintiff has suffered and will continue to suffer as a result of the acts described in Item I. above since January 28, 2017.
- III. In all other respects, the action is dismissed as currently unfounded.
- IV. In response to the counterclaim, it is determined that the Plaintiff shall compensate the Defendant for all damages suffered by the Defendant since XXXXXX as a result of the Plaintiff's and XXXX's failure to fulfill XXXX's claim to enter into a license agreement, which includes the patent in suit, on reasonable and non-discriminatory terms.
- V. The Plaintiff is ordered to pay 80% of the costs of the proceedings and the Defendant 20%.
- VI. The judgment is provisionally enforceable for the Plaintiff with respect to item I. against security in the amount of EUR 250,000.00 and for both parties with respect to item V. against security in the amount of 110% of the respective amount to be enforced.

VII. The amount in dispute is set at EUR 2,500,000.00.

### **Facts of the Case:**

The Plaintiff asserts - as the registered owner with sole right of disposal - claims for injunction, information and rendering of accounts, recall and destruction as well as determination of the obligation to pay damages on the merits due to infringement of the German part of the European patent EP XXX (Annex ES 2, submitted in German translation as Annex ES 2b; hereinafter: Patent in suit), which was filed by claiming two US-American priorities XXX and disclosed as application on XXX. The notice of grant of the patent in suit was published on XXX. The patent in suit is in force with effect for the Federal Republic of Germany. No decision has yet been taken on the action for annulment filed by the Defendant with the Federal Patent Court (XXX) in a written statement dated XXX (cf. Annex B 4).

The patent in suit relates to the field of picture (de)coding with a short delay. Claims 1 and 15 of the patent in suit - filed and granted in English - read:

*"1. Decoder for reconstructing a picture (10) from a datastream (12) into which the picture is coded in units of slices (14) into which the picture (10) is partitioned, wherein the decoder is configured to decode the slices (14) from the datastream (12) in accordance with a slice order (16) and the decoder is responsive to a syntax element portion (18) within a current slice of the slices, so as to decode the current slice in accordance with one of at least two modes (20, 22), and in accordance with a first (20) of the at least two modes, decode the current slice from the datastream (12) using context adaptive entropy decoding (24) including a derivation of contexts across slice boundaries, a continuous update of symbol probabilities of the contexts and an initialization (38, 40) of the symbol probabilities depending on saved states of symbol probabilities of a previously decoded slice, and predictive decoding across the slice boundaries, and in accordance with a second (22) of the at least two modes, decode the current slice from the datastream (12) using context adaptive entropy decoding with restricting the derivation of the contexts so as to not cross the slice boundaries, a continuous update of symbol probabilities of the contexts and an initialization of the symbol probabilities independent on any previously decoded slice, and predictive decoding with restricting the predictive decoding so as to not cross the slice boundaries, wherein the picture (10) is partitioned in coding blocks (32)*

arranged in rows and columns and having a raster scan order (36) defined among each other, and the decoder is configured to associate each slice (14) with a continuous subset of the coding blocks (32) in the raster scan order (36) so that the subsets follow each other along the raster scan order (36) in accordance with the slice order, and wherein the decoder is configured to save symbol probabilities as obtained in context adaptive entropy decoding the previously decoded slice up to a second coding block (32) in a row in accordance with the raster scan order (36), and, in initializing the symbol probabilities for the context adaptive entropy decoding of the current slice in accordance with the first mode, check as to whether a first coding block of the continuous subset of coding blocks (32) associated with the current slice is a first coding block (32) in a row in accordance with the raster scan order, and, if so, initialize (40) the symbol probabilities for the context adaptive entropy decoding of the current slice depending on the saved symbol probabilities as obtained in context adaptive entropy decoding the previously decoded slice up to a second coding block in a row in accordance with the raster scan order (36), and, if not, initialize (38) the symbol probabilities for the context adaptive entropy decoding of the current slice depending on symbol probabilities as obtained in context adaptive entropy decoding the previously decoded slice up to the end of the previously decoded slice.

15. Method for reconstructing a picture (10) from a datastream (12) into which the picture is coded in units of slices (14) into which the picture (10) is partitioned, wherein the method comprises decoding the slices (14) from the datastream (12) in accordance with a slice order (16) and the method is responsive to a syntax element portion (18) within a current slice of the slices, so as to decode the current slice in accordance with one of at least two modes (20, 22), wherein in accordance with a first (20) of the at least two modes, the current slice is decoded from the datastream (12) using context adaptive entropy decoding (24) including a derivation of contexts across slice boundaries, a continuous update of symbol probabilities of the contexts and an initialization (38, 40) of the symbol probabilities depending on saved states of symbol probabilities of a previously decoded slice, and predictive decoding across the slice boundaries, and in accordance with a second (22) of the at least two modes, the current slice is decoded from the datastream (12) using context adaptive entropy decoding with restricting the derivation of the contexts so as to not cross the slice boundaries, a continuous update of symbol probabilities of the contexts and an initialization of the symbol probabilities independent on any previously decoded slice, and predictive decoding with restricting the predictive decoding so as to not cross the slice boundaries, wherein the picture (10) is partitioned in coding blocks (32) arranged in rows and columns and having a raster scan order (36) defined among each other, and the method comprises associating each



*slice (14) with a continuous subset of the coding blocks (32) in the raster scan order (36) so that the subsets follow each other along the raster scan order (36) in accordance with the slice order, and wherein the method comprises saving symbol probabilities as obtained in context adaptive entropy decoding the previously decoded slice up to a second coding block (32) in a row in accordance with the raster scan order (36), and, in initializing the symbol probabilities for the context adaptive entropy decoding of the current slice in accordance with the first mode, checking as to whether a first coding block of the continuous subset of coding blocks (32) associated with the current slice is a first coding block (32) in a row in accordance with the raster scan order, and, if so, initializing (40) the symbol probabilities for the context adaptive entropy decoding of the current slice depending on the saved symbol probabilities as obtained in context adaptive entropy decoding the previously decoded slice up to a second coding block in a row in accordance with the raster scan order (36), and, if not, initializing (38) the symbol probabilities for the context adaptive entropy decoding of the current slice depending on symbol probabilities as obtained in context adaptive entropy decoding the previously decoded slice up to the end of the previously decoded slice.“*

Translated, claim 1 reads:

*"1. Ein Decodierer zum Rekonstruieren eines Bildes (10) aus einem Datenstrom (12), in den das Bild in Einheiten von Stücken (14) codiert ist, in die das Bild (10) partitioniert ist, wobei der Decodierer dazu ausgebildet ist, die Stücke (14) gemäß einer Stückreihenfolge (16) aus dem Datenstrom (12) zu decodieren, und der Decodierer auf einen Syntaxelementabschnitt (18) innerhalb eines aktuellen Stückes der Stücke anspricht, um das aktuelle Stück gemäß einem von zumindest zwei Modi (20, 22) zu decodieren, und das aktuelle Stück gemäß einem ersten (20) der zumindest zwei Modi unter Verwendung von kontextadaptiver Entropiedecodierung (24) einschließlich einer Ableitung von Kontexten über Stückgrenzen hinweg, einer fortlaufenden Aktualisierung von Symbolwahrscheinlichkeiten der Kontexte und einer Initialisierung (38, 40) der Symbolwahrscheinlichkeiten abhängig von gespeicherten Zuständen von Symbolwahrscheinlichkeiten eines zuvor decodierten Stückes, sowie voraussagender Decodierung über die Stückgrenzen hinweg aus dem Datenstrom (12) zu decodieren, und das aktuelle Stück gemäß einem zweiten (22) der zumindest zwei Modi unter Verwendung von kontextadaptiver Entropiedecodierung mit einem Beschränken der Ableitung der Kontexte, um die Stückgrenzen nicht zu überschreiten, einer fortlaufenden Aktualisierung von Symbolwahrscheinlichkeiten der Kontexte und einer Initialisierung der Symbolwahrscheinlichkeiten unabhängig von jeglichem zuvor decodierten Stück, sowie voraussagender Decodierung mit*

einem Beschränken der voraussagenden Decodierung, um die Stückgrenzen nicht zu überschreiten, aus dem Datenstrom (12) zu decodieren und wobei das Bild (10) in Codierblöcke (32) partitioniert ist, die in Zeilen und Spalten angeordnet sind und eine untereinander definierte Rasterabtastrihenfolge (36) aufweisen, und der Decodierer dazu ausgebildet ist, jedes Stück (14) einem fortlaufenden Teilsatz der Codierblöcke (32) in der Rasterabtastrihenfolge (36) zuzuordnen, so dass die Teilsätze einander entlang der Rasterabtastrihenfolge (36) gemäß der Stückreihenfolge folgen, und wobei der Decodierer dazu ausgebildet ist, Symbolwahrscheinlichkeiten, wie bei einer kontextadaptiven Entropiedecodierung des zuvor decodierten Stückes bis zu einem zweiten Codierblock (32) in einer Zeile gemäß der Rasterabtastrihenfolge (36) erhalten, zu speichern, und bei einem Initialisieren der Symbolwahrscheinlichkeiten für die kontextadaptive Entropiedecodierung des aktuellen Stückes gemäß dem ersten Modus zu überprüfen, ob ein erster Codierblock des fortlaufenden Teilsatzes von Codierblöcken (32), der dem aktuellen Stück zugeordnet ist, ein erster Codierblock (32) in einer Zeile gemäß der Rasterabtastrihenfolge ist, und, falls dies zutrifft, die Symbolwahrscheinlichkeiten für die kontextadaptive Entropiedecodierung des aktuellen Stückes abhängig von den gespeicherten Symbolwahrscheinlichkeiten, wie bei der kontextadaptiven Entropiedecodierung des zuvor decodierten Stückes bis zu einem zweiten Codierblock in einer Zeile gemäß der Rasterabtastrihenfolge (36) erhalten, zu initialisieren (40), und, falls dies nicht zutrifft, die Symbolwahrscheinlichkeiten für die kontextadaptive Entropiedecodierung des aktuellen Stückes abhängig von Symbolwahrscheinlichkeiten, wie bei der kontextadaptiven Entropiedecodierung des zuvor decodierten Stückes bis zu dem Ende des zuvor decodierten Stückes erhalten, zu initialisieren (38).

15. Ein Verfahren zum Rekonstruieren eines Bildes (10) aus einem Datenstrom (12), in den das Bild in Einheiten von Stücken (14) codiert ist, in die das Bild (10) partitioniert ist, wobei das Verfahren ein Decodieren der Stücke (14) aus dem Datenstrom (12) gemäß einer Stückreihenfolge (16) aufweist, und das Verfahren auf einen Syntaxelementabschnitt (18) innerhalb eines aktuellen Stückes der Stücke anspricht, um das aktuelle Stück gemäß einem von zumindest zwei Modi (20, 22) zu decodieren, wobei das aktuelle Stück gemäß einem ersten (20) der zumindest zwei Modi unter Verwendung von kontextadaptiver Entropiedecodierung (24) einschließlich einer Ableitung von Kontexten über Stückgrenzen hinweg, einer fortlaufenden Aktualisierung von Symbolwahrscheinlichkeiten der Kontexte und einer Initialisierung (38, 40) der Symbolwahrscheinlichkeiten abhängig von gespeicherten Zuständen von Symbolwahrscheinlichkeiten eines decodierten Stückes, sowie voraussagender Decodierung über die Stückgrenzen hinweg aus dem Datenstrom (12) decodiert wird, und das aktuelle Stück gemäß einem zweiten (22) der zumindest zwei

*Modi unter Verwendung von kontextadaptiver Entropiedecodierung mit einem Beschränken der Ableitung der Kontexte, um die Stückgrenzen nicht zu überschreiten, einer fortlaufenden Aktualisierung von Symbolwahrscheinlichkeiten der Kontexte und einer Initialisierung der Symbolwahrscheinlichkeiten unabhängig von jeglichem zuvor decodierten Stück, sowie voraussagender Decodierung mit einem Beschränken der voraussagenden Decodierung, um die Stückgrenzen nicht zu überschreiten, aus dem Datenstrom (12) decodiert wird, wobei das Bild (10) in Codierblöcke (32) partitioniert ist, die in Zeilen und Spalten angeordnet sind und eine untereinander definierte Rasterabtastreihenfolge (36) aufweisen, und das Verfahren ein Zuordnen jedes Stückes (14) zu einem fortlaufenden Teilsatz der Codierblöcke (32) in der Rasterabtastreihenfolge (36) aufweist, so dass die Teilsätze einander entlang der Rasterabtastreihenfolge (36) gemäß der Stückreihenfolge folgen, und wobei das Verfahren ein Speichern von Symbolwahrscheinlichkeiten, wie bei einer kontextadaptiven Entropiedecodierung des zuvor decodierten Stückes bis zu einem zweiten Codierblock (32) in einer Zeile gemäß der Rasterabtastreihenfolge (36) erhalten, und bei einem Initialisieren der Symbolwahrscheinlichkeiten für die kontextadaptive Entropiedecodierung des aktuellen Stückes gemäß dem ersten Modus ein Überprüfen, ob ein erster Codierblock des fortlaufenden Teilsatzes von Codierblöcken (32), der dem aktuellen Stück zugeordnet ist, ein erster Codierblock (32) in einer Zeile gemäß der Rasterabtastreihenfolge ist, und, falls dies zutrifft, ein Initialisieren (40) der Symbolwahrscheinlichkeiten für die kontextadaptive Entropiedecodierung des aktuellen Stückes abhängig von den gespeicherten Symbolwahrscheinlichkeiten, wie bei einer kontextadaptiven Entropiedecodierung des zuvor decodierten Stückes bis zu einem zweiten Codierblock in einer Zeile gemäß der Rasterabtastreihenfolge (36) erhalten, und falls dies nicht zutrifft, ein Initialisieren (38) der Symbolwahrscheinlichkeiten für die kontextadaptive Entropiedecodierung des aktuellen Stückes abhängig von Symbolwahrscheinlichkeiten, wie bei einer kontextadaptiven Entropiedecodierung des zuvor decodierten Stückes bis zu dem Ende des zuvor decodierten Stückes erhalten, aufweist.“*

The figures reproduced in reduced form below are taken from the patent in suit and explain its technical teachings on the basis of preferred examples of embodiment:

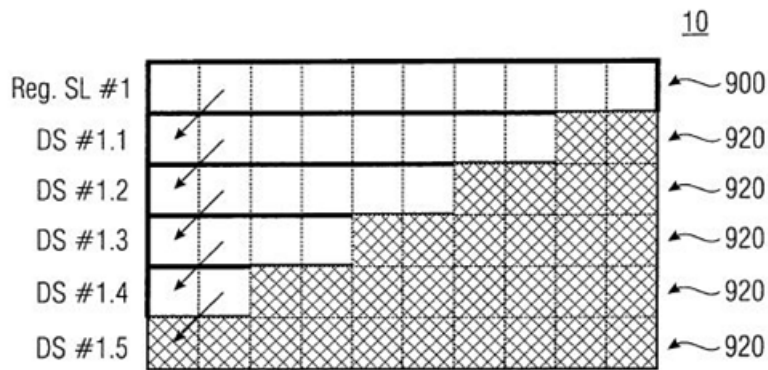

FIG 14

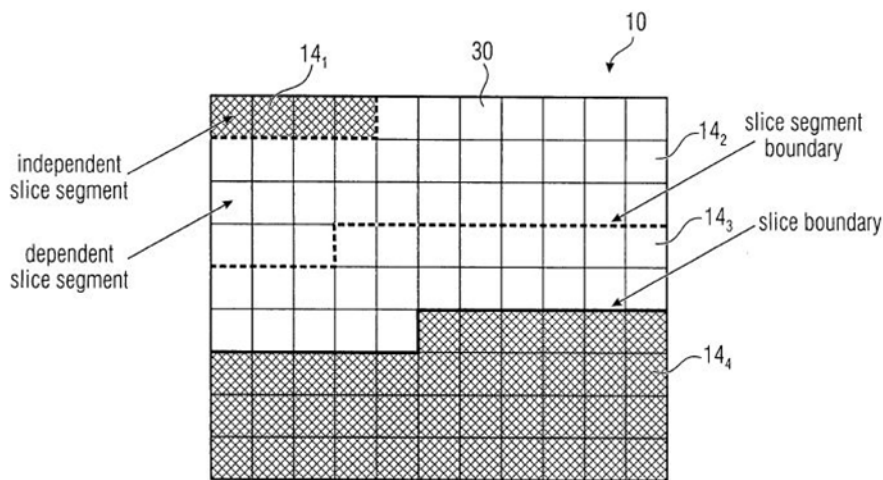

FIG 27

Figure 14 shows an example of partitioning a picture for wavefront parallel processing (WPP) into a regular slice and, for low processing delay, dependent slices. Figure 27 shows the partitioning of a picture into regular and dependent slices, here also called slice segments.

The Plaintiff is a subsidiary of XXX and acquired a patent portfolio from XXX years ago, which included the patent in suit here.

The Defendant is the German subsidiary of XXX, which is one of the world's largest manufacturers of TV sets and set-top boxes. In this respect, the Defendant acts as a sales company for the regions Germany, Austria and Switzerland and also operates the German-language website [XXX](#), via which, among other things, HEVC-capable TV

sets and set-top boxes are also offered under the various brands of XXX (hereinafter: impugned embodiments). Via the website of the Defendant, inter alia, the XXX product catalog submitted as Exhibit ES 3b to the file can be accessed, in which televisions with 4K Ultra HD feature are also advertised and, in addition, the statement is made that the televisions support the DVB-T2 standard for terrestrial television, which is now widespread in Germany. In addition, televisions of the XXX brand are available in Germany via various (Internet) retailers such as XXX and XXX, which are advertised as being compatible with the HECV standard and whose operating instructions state the Defendant as the importer and distributor (see Annex ES 3c).

The DVB-T2 standard is the international successor standard to the DVB-T standard, which was used throughout Germany. The DVB-T2 standard is more efficient than the older DVB-T standard and allows the transmission of more programs and/or the achievement of better picture quality (so-called HDTV) with the same frequency usage. In the Federal Republic of Germany, the DVB-T2 standard makes use of the coding method according to the H.265/MPEG-H High Efficiency Video Coding - HEVC standard (hereinafter: HEVC standard), which in turn was developed by the International Telecommunication Union (ITU) as the successor standard to the H.264/MPEG-4 Advanced Video Coding - AVC standard. The Plaintiff made a SEP-FRAND declaration to the ITU. The HEVC standard was submitted by the Plaintiff in excerpts as Exhibit ES 3d to the file.

The patent in suit is part of the HEVC Advance Patent Pool (hereinafter: (Patent) Pool). At the end of the oral proceedings, the patent pool comprises a good 15,000 patents which, including the Plaintiff, have been contributed by approx. 35 licensors. Most recently, XXX and XXX joined as licensors and contributed to the Patent Pool approximately 1,200 HEVC-essential property rights, which had previously been licensed via XXX.

The pool, which according to the Plaintiff's calculations includes approximately 70% of all patents for the HEVC standard, is managed by HEVC Advance LLC of Boston, now trading as "Access Advance" (hereinafter: Advance).

In 2020, 29 licensors had contributed their IP rights to the patent pool. In addition to the Plaintiff, the licensors include companies such as XXX, XXX, XXX, XXX, XXX, XXX, XXX and XXX.

More than 160 companies were licensees of the pool in July 2020. In the meantime, their number has risen to around 225. The licensees of the pool include companies such as XXX (Annex ES-Kart 36). An overview of the licensing situation can be found in Exhibit ES 1f. to which supplementary reference is made.

In addition to the Advance patent pool, there is a pool of HEVC patents managed by MPEG LA. These two patent pools have overlapping content, the specific amount of which is in dispute between the parties and ranges from a minimum of 30% to a maximum of around 70%. XXX entered into a license agreement with MPEG LA on December 12, 2018, regarding its HEVC portfolio, which is disputed by the Plaintiff (see Exhibit GRÜ 6). In addition to XXX, there are approximately 90 other licensees that simultaneously hold a license to the MPEG LA and Advance HEVC pool.

Advance provides general information on the licensing program, the structure of the license fees (cf. Exhibit ES 1d) as well as a downloadable document of the HEVC Advance Patent Portfolio License Agreement (hereinafter also: PPL, Exhibit ES 1h) on its website at the domain [www.hevcadvance.com](http://www.hevcadvance.com). Furthermore, patent lists (claim charts) are available, which refer to corresponding passages in the standard.

The rough structure of the fee system (for contractually compliant licensees) is as follows (extract from Annex ES 1e):

## Royalty Rate Structure for Licensees In-Compliance with Trademark, Effective July 1, 2020

Device Category and Examples	Selling Price	Per-Device Royalty <sup>(1)</sup> Main Profiles	Advanced Profiles Royalty <sup>(1)</sup> (Each)	Advanced Profiles Royalty <sup>(1)</sup> (All Three)	Annual In-Compliance Device Category Caps <sup>(2)</sup> for the Period up to 1/1/2021	Annual In-Compliance Device Category Caps <sup>(2)</sup> for the Period on/after 1/1/2021 unless suspension applies <sup>(1)</sup>	Annual In-Compliance Enterprise Credit and Cap <sup>(3)</sup> for the Period up to 1/1/2021	Annual In-Compliance Enterprise Credit and Cap <sup>(3)</sup> for the Period on/after 1/1/2021 unless suspension applies <sup>(1)</sup>
<b>Mobile Devices:</b> Mobile Phone, Tablet, Laptop	All price ranges	\$0.40/\$0.20	+\$0.10/\$0.05	+\$0.25/\$0.125	\$30MM \$20MM (if entity does not sell phones)	\$36MM \$24MM (if entity does not sell phones)		
<b>Connected Home &amp; Other Devices:</b> <u>Consumer Products:</u> Set-Top Box, Game Console, Blu-ray Player, Desktop PC, non-4k UHD+ TV, HEVC Software  <u>Authorized Commercial Products:</u> Surveillance Cameras, Conferencing Products, Medical Imaging, Digital Signage	Devices ≤\$80.00 <sup>(4)</sup>	\$0.20/\$0.20 \$0.25/\$0.25 \$0.35/\$0.35 \$0.45/\$0.40 \$0.55/\$0.40 \$0.65/\$0.40 \$0.75/\$0.40	+\$0.10/\$0.05	+\$0.25/\$0.125	\$20MM	\$24MM	Annual Enterprise Cap \$40 million	Annual Enterprise Credit \$25,000
	Devices >\$80.00 <sup>(5)</sup> and All HEVC Software	\$0.80/\$0.40						
<b>4K UHD+ Televisions</b>	All price ranges	\$1.20/\$0.60	+\$0.30/\$0.15	+\$0.75/\$0.375	\$20MM	\$24MM		
<b>Digital Media Storage</b> Blu-ray Discs, Other Storage Devices	All price ranges	Per Disc/Title \$.0225/\$.01125	\$0.00	\$0.00	\$2.5MM	\$3.0MM		

(1) Royalties shown are Region 1/Region 2 Countries/Territories. Advanced Profiles means the three profile groups released under Version 2: (A) Multiview HEVC extensions (MV-HEVC), (B) Range extensions (Rext), and (C) Scalable HEVC extensions (SHVC).  
 (2) Excludes HEVC Software.  
 (3) For licensees before 1/1/2021, the annual caps for the renewal period on/after 1/1/2021 are "suspended" through 12/31/2025, and the pre-renewal caps for the period up to 1/1/2021 will continue to apply. After 12/31/2025, the annual caps for the period on/after 1/1/2021 will apply to all licensees (unless the suspension is extended).  
 (4) Applies to all Devices with a Selling Price of \$80 or less, excluding HEVC Software. Discounts for Devices Sold in Region 1 Countries/Territories at a Selling Price from \$40.01 to \$80 are effective for Sales on or after 1/1/2018.  
 (5) Includes Devices Sold in Region 1 Countries/Territories at a Selling Price from \$40.01 to \$80 for Sales before 1/1/2018.

Towards licensees who have not also taken a trademark license, the license fees deviate slightly upwards. Turkey is grouped in region 1, XXX. For the rest, reference is made to the pool license offer because of its further contents.

With regard to any existing license agreements for individual IP rights contributed to the HEVC patent pool, Advance provided the following procedure on its website under the heading "Duplicate Royalties Policy" (illustration taken from Exhibit GRÜ 75):

In the event a Licensor would receive duplicate royalties from a Licensee in respect of one or more Patent(s) that:

- are included in the HEVC Advance Patent Portfolio and are also included in the patent list of another patent licensing pool, or joint licensing program, which pool or program expressly encompasses the HEVC Standard and includes an overlap in the scope of the license grants under the pool or program, as applicable;

then, upon request by the Licensee<sup>(3)</sup>, or at Licensor's election, the Licensor shall reimburse<sup>(4)</sup> one of the following amounts attributable to the duplicate royalty payment:

- the net distribution<sup>(5)</sup> the Licensor received from HEVC Advance, or
- the net distribution the Licensor received from another pool or joint licensing program, or
- any other amount agreed to between the Licensor and Licensee<sup>(6)</sup>.

How this handling of duplicate royalties is to be made effective against a licensee is further set forth in the document "Duplicate Royalty Implementation Process" filed as GRÜ 76:

### Implementation Steps

**Step 1:** The Licensee makes a written request for reimbursement of duplicate royalties to the applicable Licensor(s) and/or HEVC Advance (in which case HEVC Advance will forward the request to the applicable Licensor(s)), or the Licensor makes a written request to the Licensing Administrator for reimbursement of duplicate royalties to designated Licensees. HEVC Advance will only act on a request by a Licensor to provide reimbursement to a Licensee providing the Licensee has agreed.

**Step 2:** Each applicable Licensor will then confirm that a duplicate royalty situation exists. The Licensor will then decide the basis upon which a reimbursement will be made. That is, each Licensor will decide whether to return (a) the duplicate amount (net distribution) received by the Licensor from HEVC Advance, (b) the duplicate amount (net distribution) received by the Licensor from another patent pool or joint licensing program, or (c) some other amount as the Licensor and Licensee may agree.

**Step 3:** The Licensor will then decide whether to provide the duplicate royalty reimbursement to the Licensee either (a) directly, (b) through another patent pool or joint licensing program, or (c) through HEVC Advance, and advise the Licensee and HEVC Advance of said decision.

**Step 4:** If the Licensor decides to provide the reimbursement through HEVC Advance, then the Licensor will advise HEVC Advance of its Step 2 decision. HEVC Advance will thereupon advise the Licensee and take such reasonable and necessary steps to determine the applicable amount to be reimbursed pursuant to the Licensor's decision. This would include, as required, contacting the Licensor and/or Licensee and obtaining such information necessary to determine the amount of reimbursement.

**Step 5:** HEVC Advance will thereupon make any necessary invoice adjustments and issue such adjusted invoice to the Licensee.

In spring 2017, an initial contact was made between Advance and XXX (Exhibit GRÜ 1), with which Advance advised XXX of what it considered to be a patent infringement. In December 2017, representatives of XXX, namely XXX, and of HEVC Advance, XXX, met in person to discuss entering into a license agreement. Shortly thereafter, Advance



approached customers of XXX and similarly advised them of the alleged patent infringing condition of the challenged embodiments (Summer/Fall 2017; Exhibit GRÜ 2).

In January 2018, Advance substantiated the allegation of infringement. It sent XXX initial claim charts and informed XXX that 17 patents from the pool were considered relevant with regard to infringement (Exhibit GRÜ 3). The first offer to conclude a pool license agreement was submitted by the pool administrator on May 15, 2018 (Exhibit ES 1g), which XXX had invited the Plaintiff to do by letter dated May 9, 2018 (Exhibits ES-Kart 2, ES-Kart 3).

During a face-to-face meeting of the Parties in XXX on June 11, 2018, XXX was handed Advance's white paper, submitted as Exhibit ES 1e 1/2, and additional claim charts. This was a meeting dominated by technical issues. On July 11, 2018, Advance pointed out other patents held by other owners that would also be infringed. It also pointed out the possibility of entering into bilateral licensing agreements.

In mid-November 2018, the parties again met in person to initiate the conclusion of a license agreement. To this end, the parties discussed the submission of settlement license agreements and the conditions, such as the conclusion of an NDA, under which this could be made possible. Discussions also included the amount of the license fee, which the Defendant considered to be translated. Since the first meetings, the parties also addressed the handling of the fee amount in view of HEVC patents already licensed outside the Advance Pool.

In January 2019, XXX brought an action against Advance and XXX in the London High Court of Justice (Exhibit ES 1h and Exhibit GRÜ 7, respectively). In so doing, it sought, in particular, a declaration that the royalties contained in its counter-offer of XXX to Advance (Exhibit GRÜ 8) were FRAND. Both at first and second instance, the action was dismissed for lack of jurisdiction of the court seized (Annex ES 1i; Annex ES-Kart 9).

A meeting of the parties took place in XXX at the end of April 2019. The main topics discussed there were payments for the past and the amount of future license fees. Another point of discussion between the parties was the provision of information on sales figures by XXX. Advance repeatedly asked for such information and repeatedly clarified the details of the information provided, in particular with regard to the brand under which they were sold and the company for which they were manufactured. In this regard, XXX submitted information on products distributed in the period from December 31, 2018 to August 31, 2020 (Exhibit GRÜ 20, GRÜ 22). Due to the exchange on this issue, reference is made to the e-mails submitted as Annexes GRÜ 26 et seq. to the file.

On July 24, 2020, XXX filed suit in The Hague against XXX, XXX and Advance (Exhibit GRÜ 11); the suit was extended against XXX on August 31, 2020 (Exhibit GRÜ 12). In this way, the Respondent continues to pursue its interest in reaching a judicial determination of a FRAND fee, and its counteroffer should also be used as a basis here. A decision in these disputes has not yet been issued.

The exchange between the parties on the terms of the contract continued until the middle of the year 2021 (cf. annex volume ES-Kart 35). In March 2021, the Plaintiff XXX submitted an updated offer with regard to the lump-sum compensation payment for the past. The Plaintiff had already previously updated its pool offer on October 21, 2020 and November 6, 2020 (see Exhibit ES-Kart 14 et seq.). For its part, the Defendant again updated its counter-offer in September 2021, again with a higher license fee of now USD XXX (Exhibit GRÜ 105).

The Plaintiff personally submitted a bilateral license offer to XXX in April 2019 (Exhibit ES11), which provided for a license fee in the amount of USD XXX. The Plaintiff did not accept XXX counter-offer from November 2020 (see Exhibit GRÜ 58). The subsequent correspondence between the parties ultimately did not lead to the conclusion of a contract. The Plaintiff has not concluded any bilateral license agreements to date.

Apart from the present litigation, the Plaintiff is conducting proceedings for patent infringement against the Defendant under file number XXX. In addition, the other pool members XXX are asserting claims against the Defendant under one and two (XXX) pool patents, respectively, in litigation also conducted before the Board.

The Plaintiff is of the opinion that the HEVC standard and consequently also the challenged embodiments make use of the teaching of the patent in suit.

The patent in suit - as is already clear from paragraph [0015] - is intended to further develop the generally known slice concept, so that it is not based solely on the conventional understanding of the term slice in video (de)encoding. It therefore provides for a departure from the principle, valid until then, that the boundaries of a slice must always break the prediction. In this respect, it provides for the subdivision of the slice into independent and dependent slices. It is true that in paragraph [0154] of the patent in suit a break in the nomenclature can be recognized, since up to this passage only (in)dependent slices are mentioned, whereas subsequently the terms (in)dependent slice segments are introduced. The patent in suit, however, would explicitly clarify that it wants to understand the terms slice and slice segment synonymously. This technical understanding is also apparent from section 3.3.1 of the reference book "High Efficiency Video Coding (HEVC) - Algorithms and Architectures" by Sze V. *et al.* (excerpts submitted as Exhibit ES 3e).

The teaching of the patent in suit does not only concern the coding side of the standard, since the decoder must also be able to process the two proposed modes. Also, the teaching of the patent in suit does not provide an own choice for the decoder, but the decoder should respond to a syntax element section determined by the coder, which tells it from case to case which mode to use. Depending on the value of the element "dependent\_slice\_segment\_flag", i.e. the presence of a dependent or independent

slice segment, the variable "SliceAddrRs" is set to a new value or not. If two blocks had the same value "SliceAddrRs", the neighboring block would be available for coding.

Furthermore, the Plaintiff is of the opinion that the patent in suit will prove to be legally valid in the decision on the Defendant's action for revocation.

According to the Plaintiff, the antitrust objection raised by the Defendant is unfounded and the claims for injunction, recall and destruction are currently enforceable. The Defendant had already shown itself unwilling to license. XXX had not responded to the infringement notice in 2017. In the subsequent period, special efforts to nevertheless be considered willing to be licensed were not made. All the more, the foreign parallel proceedings initiated would prove the lack of willingness to license, especially since applications for the issuance of an anti-suit injunction had been filed there. XXX was using delaying tactics to prevent the conclusion of a license agreement. This was also evident from the slow exchange of information on the conclusion of an NDA, which was intended to enable the Plaintiff to submit settlement license agreements. Nor could the counter-offer submitted be taken seriously. Advance's standard pool license offer, on the other hand, was not objectionable in terms of content and did not lead to any exploitative abuse at the expense of the Defendant. In particular, the Plaintiff's handling of the compensation for duplicate royalties as described in the Duplicate Royalties Policy is in compliance with FRAND. It was a matter for the duplicate licensors and the license seeker to find a compensation mechanism. It is not possible to specify the amount of the fee to be refunded to the Defendant, as this depends on information from the Defendant, which is only available during an ongoing licensing relationship after an accounting period. Furthermore, the large number of license agreements already concluded speaks in favor of FRAND compliance. These licensees had not taken any offense at the refund policy. This is a considerable indication of fair and reasonable contractual terms. In addition, according to the Plaintiff, other patent pools proceeded in the same way and also did not provide for a specific regulation for the reimbursement of double royalties. At least with regard to the MPEG LA HEVC pool, the Defendant

had also accepted such a regulation. Moreover, Advance was not able to deviate from the standard license agreement in favor of the Defendant with regard to certain parameters of the license agreement.

Furthermore, the objection to a compulsory license under antitrust law was also unfounded with regard to the bilateral license offer submitted by the Plaintiff. The Plaintiff had fulfilled its FRAND obligations. The license fee amount of USD XXX for 4k/UHD televisions is based on the HEVC pool license fees and is also based on the share of the Plaintiff's patents in the pool plus a XXX surcharge for administrative costs incurred. These are justified by the fact that the Plaintiff, unlike a patent pool, can license less efficiently. The special advantages of pool licensing would no longer apply. Irrespective of this, the Defendant was not interested in a bilateral licensing, which resulted from the counteroffer from November 2020 together with the related correspondence (see attachment ES-Kart 19).

The Plaintiff requests,

- I. The Defendant be ordered to,
  1. to cease and desist from any infringement of this provision upon avoidance of an orderly fine of up to EUR 250,000 for each infringement - or, in the event of repeated infringements, of up to a total of 2 years' imprisonment, with the orderly imprisonment to be enforced on the Defendant's managing director,

to offer, place on the market, use or either import or possess for the aforementioned purposes in the Federal Republic of Germany:

- a) A decoder for reconstructing a picture from a datastream into which the picture is coded in units of slices into which the picture is partitioned, wherein the decoder is configured to decode the slices from the datastream in accordance with a slice order and the decoder is responsive to a syntax element portion within a current slice of the slices, so as to decode the current slice of the slices in accordance with one of at least two modes, and

in accordance with a first of the at least two modes, decode the current slice from the datastream using context adaptive entropy decoding including a derivation of contexts across slice boundaries, a continuous update of symbol probabilities of the contexts and an initiali-

zation of the symbol probabilities depending on saved states of symbol probabilities of a previously decoded slice, and predictive decoding across the slice boundaries from the datastream; and

decoding the current slice from the datastream in accordance with a second of the at least two modes using context adaptive entropy decoding with restricting the derivation of the contexts so as to not cross the slice boundaries, a continuous update of symbol probabilities of the contexts, and an initialization of the symbol probabilities independently of any previously decoded slice, and predictive decoding with restricting the predictive decoding so as to not cross the slice boundaries; and

wherein the picture is partitioned into coding blocks arranged in rows and columns and having a raster scan order defined with respect to each other, and the decoder is adapted to associate each slice with a consecutive subset of the coding blocks in the raster scan order so that the subsets follow each other along the raster scan order according to the slice order, and

wherein the decoder is configured to save symbol probabilities as obtained in a context adaptive entropy decoding of the previously decoded slice up to a second coding block in a row in accordance with the raster scan order, and, upon initializing the symbol probabilities for the context adaptive entropy decoding of the current slice in accordance with the first mode, checking whether a first coding block of the continuous subset of coding blocks associated with the current slice is a first coding block in a row in accordance with the raster scan order, and, if so initialize the symbol probabilities for the context adaptive entropy decoding of the current slice depending on the saved symbol probabilities, as obtained in the context adaptive entropy decoding of the previously decoded slice, up to a second coding block in a row in accordance with the raster scan order, and, if not, initializing the symbol probabilities for the context adaptive entropy decoding of the current slice depending on symbol probabilities as obtained in the context adaptive entropy decoding of the previously decoded slice up to the end of the previously decoded slice.

- b) To offer or supply for use in the Federal Republic of Germany to third parties in the Federal Republic of Germany:

Means for performing a method of reconstructing a picture from a datastream into which the picture is coded in units of slices into which the picture is partitioned, wherein the method comprises decoding the slices from the datastream in accordance with a slice order and the method being responsive to a syntax element portion within a current slice of the slices, so as to decode the current slice in accordance with one of at least two modes, wherein

in accordance with a first of the at least two modes the current slice is decoded from the datastream using context adaptive entropy decoding including derivation of contexts across slice boundaries, a continuous update of symbol probabilities of the contexts and an initialization of the symbol probabilities depending on saved states of symbol probabilities of a decoded slice, and predictive decoding across the slice boundaries, and in accordance with a second of the at least two modes, the current slice is decoded from the datastream using context adaptive entropy decoding with restricting the derivation of the contexts so as to not cross the slice boundaries, a continuous update of symbol probabilities of the contexts and initialization of the symbol probabilities independent of any previously decoded slice, and predictive decoding with restricting the predictive decoding so as to not cross the slice boundaries,

wherein the picture is partitioned in coding blocks arranged in rows and columns and having a raster scan order defined with respect to each other, and the method comprises associating each slice to a continuous subset of the coding blocks in the raster scan order so that the subsets follow each other along the raster scan order in accordance with the slice order, and wherein the method comprises saving symbol probabilities as obtained in context adaptive entropy decoding of the previously decoded slice up to a second coding block in a row in accordance with the raster scan order, and, in initializing the symbol probabilities for context adaptive entropy decoding of the current slice in accordance with the first mode, checking whether a

first coding block of the continuous subset of coding blocks, associated with the current slice is a first coding block in a row in accordance with the raster scan order, and, if so, initializing the symbol probabilities for the context adaptive entropy decoding of the current slice depending on the saved symbol probabilities as obtained in a context adaptive entropy decoding of the previously decoded slice up to a second coding block in a row in accordance with the raster scan order, and, if not, initializing the symbol probabilities for the context-adaptive entropy decoding of the current slice depending on symbol probabilities as obtained in a context adaptive entropy decoding of the previously decoded slice up to the end of the previously decoded slice.

2. To provide the Plaintiff in a separate statement, also in electronic form - with regard to statements a) and b) by submitting invoices, alternatively delivery bills, further alternatively receipts in copy, whereby data to which the owed information and accounting does not refer and with regard to which a justified interest in secrecy of the Defendant exists, may be covered or blacked out - with regard to the extent to which it has committed the acts referred to under 1.a) and 1.b) since January 28, 2017, indicating:
  - a) the quantity of products received or ordered and the names and addresses of manufacturers, suppliers and other previous owners,
  - b) of the individual deliveries, broken down by delivery quantities, times and prices, the respective type designations and the names and addresses of the customers,
  - c) of the individual offers, broken down by offer quantities, times and prices, the respective type designations and the names and addresses of the recipients of the offers,
  - d) the advertising carried out, broken down by advertising medium, its circulation volume, distribution period and distribution area, and in the case of Internet advertising, the domain, access figures and placement periods, and
  - e) of the prime costs broken down by the individual cost factors and the profit generated,



whereby the Defendant reserves the right to disclose the names and addresses of the non-commercial customers and offerees instead of the Plaintiff to a certified public accountant domiciled in the Federal Republic of Germany to be designated by the Defendant and bound to secrecy vis-à-vis the Plaintiff, provided that the Defendant bears the costs thereof and authorizes and obligates him to inform the Plaintiff upon specific request whether a certain customer or offeree is included in the list;

3. To hand over, at its - the Defendant's - expense, to a bailiff to be appointed by the Plaintiff, for the purpose of destruction, the products (decoders) which are in its direct or indirect possession or ownership and which are referred to in item 1.a);
  4. To recall the products (decoders) already placed on the market and referred to in item 1.a) from the commercial customers with reference to the patent-infringing condition of the product as determined by the court (judgment of the Düsseldorf District Court of ... ) and with the binding promise to reimburse any fees and to assume any necessary packaging and transport costs as well as customs and storage costs associated with the return and to take back the products;
- II. Declare that the Defendant is obliged to compensate the Plaintiff for all damage that it has suffered and will continue to suffer as a result of the acts referred to in points I.1.a) and I.1.b) since January 28, 2017.

The Defendant requests,

- I. to stay the proceedings until the final conclusion of the proceedings between the Plaintiff, XXX and XXX and the Defendant before the Legal Bank of The Hague, as initiated by the action of July 24, 2020;
- II. dismiss the action;
- III. in the alternative to II.
  1. dismiss the action as currently unfounded with respect to the claims for injunctive relief, recall and removal from the channels of distribution, and destruction;
  2. counterclaiming:

declare that the Plaintiff shall compensate the Defendant for all damages suffered by the Defendant since XXX as a result of the Plaintiff's and Access Advance LLC's failure to satisfy XXX's claim to enter into a license agreement, which includes the patent in suit, on reasonable and non-discriminatory terms;

IV. further alternatively

1. suspend the proceedings;
2. to refer the following questions to the ECJ for clarification:

Concretization of the requirements from the decision of the Court of Justice in Huawei vs. ZTE (judgement of 16.07.2015 -10-170/13):

1. Irrespective of the fact that the SEP holder and the SEP user have to fulfill their mutual duties to act (infringement notice, licensing request, FRAND license offer; license offer to the supplier to be licensed with priority) before the court, is it possible to make up for duties to act that were neglected in the pre-court area by legally preserving them in the course of court proceedings?
2. Can a considerable licensing request by the patent user only be assumed if, based on a comprehensive assessment of all accompanying circumstances, the SEP user's will and willingness to conclude a license agreement with the SEP holder on FRAND terms clearly and unambiguously emerges, whatever these FRAND terms (which, in the absence of a license offer formulated at that time, are not yet foreseeable at all) may look like?
  - a) Does an infringer who remains silent for several months in response to the infringement notice thereby regularly indicate that he is not interested in taking a license, so that - despite a verbally formulated license request - there is no such request, with the consequence that the SEP holder's action for injunctive relief must be granted?
  - b) Can a lack of license request be inferred from license conditions which the SEP user has introduced with a counter-offer, with the consequence that the SEP holder's injunction action is granted thereupon without prior examination of whether the SEP holder's own license offer (which preceded the SEP user's counter-offer) complies with FRAND conditions at all?

- c) Is such a conclusion prohibited in any case if those license conditions of the counteroffer from which a lack of license request is to be inferred are those for which it is neither obvious nor clarified by the highest courts that they cannot be reconciled with FRAND conditions?

V. Further in the alternative - each to II., III. and IV. - insofar as the board found infringement of the patent in suit and found the Plaintiff's claims to be well-founded:

To stay the proceedings until a final decision has been reached on the nullity action brought by the Defendant against the patent in suit with effect for Germany before the Federal Patent Court (XXX);

VI. Further in the alternative:

to grant the Defendant a period of grace until the products according to claim I.1. a. of the request, as well as means according to claim I.1. b of the request, as well as core-equivalent embodiments, which have been ordered by customers of the Defendant until the pronouncement of the judgment, have been delivered, plus a period of two months, however, for a maximum period of six months from the pronouncement of the judgment.

The Plaintiff requests,

dismiss the Defendant's counterclaim.

According to the Defendant, the teaching of the patent in suit is not essential to the HEVC standard.

Contrary to the view of the Plaintiff, the patent in suit would technically distinguish between a slice and a slice segment, so that these two terms would not be used synonymously. The patent in suit understands a slice - as usual in the video (de)coding standards AVC and HEVC - as a certain number of picture blocks which would be formed for the coding/decoding. In contrast, a slice segment is a specific number of blocks within a slice. It follows from this that the patent in suit also distinguishes between the boundaries of the slices (slice boundaries) and the boundaries of the slice

segments (slice segment boundaries). The patent in suit, however, would only be concerned with preventing a breaking of the prediction across slice boundaries (slice boundaries) in certain cases.

In this respect, the HEVC standard and therefore also the challenged embodiments would not make use of the teaching of the patent in suit.

Thus, the teaching of the patent in suit already refers to the coding side alone, since the decoder has no influence on which modes the coding device uses. Therefore, there is also no choice implemented in the decoder as to which mode it uses. Since the decoder has to follow the decision of the coder, it is also irrelevant for the decoder whether the slices to be decoded are independent or dependent slices.

The concept of dependent slices has not found its way into the HEVC standard. The HEVC standard would rather rely on a division of slices into separately transmittable segments, whereby only the boundaries between the slice segments may be broken, but not the boundaries between the slices themselves. A slice in the HEVC standard could therefore consist of a single independent slice segment or of one independent and one to several dependent slice segments, whereby in the latter case the independent slice segment would always have to form the first segment. Accordingly, the syntax element "dependent\_slice\_segment\_flag" would also only determine whether certain values from the slice header should be taken over for a slice segment; however, this would not break any slice boundaries (slice boundaries). The same applies to the variable "SliceAddrRs". As can be seen from section 7.4.7.1 of the HEVC standard, this variable is set to a new value for each independent slice segment, so that no slice boundaries are broken. As far as process 6.4.1 also refers to the variable "SliceAddrRs", this is relevant for whether a neighboring block is available for coding or not. However, only blocks within a slice may be used, since the variable for blocks of different slices is also different in each case and therefore the "availableN" flag is set to FALSE, so that no neighboring block is available.

Furthermore, the Defendant believes that the objection raised under antitrust law is valid.

The Defendant itself had shown itself willing to license. The proceedings originally conducted in the United Kingdom and the proceedings conducted in the Netherlands prove the willingness to license, because the Defendant wants to have the FRAND compliance of its counteroffer determined. It also resulted from the fact that the Defendant had already taken an MPEG LA HEVC license. In contrast, it was the Plaintiff that did not seriously negotiate and respond to the Defendant's positions.

In addition, the license agreement offers submitted were neither fair nor reasonable. This applies in particular to the provisions on double royalty payments. It is not compatible with FRAND principles to first demand royalties also for IP rights already licensed in and only subsequently to offer compensation, which is moreover passed on to negotiations between the respective licensors and licensees. None of the reasons provided by the Plaintiff could justify this approach and none of the license offers took this situation into account. Irrespective of this, a licensor who changes the pool from MPEG LA to Advance changes its licensing practice to the detriment of future licensees. The reference to concluded settlement license agreements is all the less successful, since with XXX at most a company is a licensee which as XX manufacturer is comparable with the company of the Defendant. Therefore, other license agreements could not be referred to.

The claim for damages pursued with the counterclaim was well-founded. The inclusion of a parent company is recognized in FRAND constellations; an offer is usually made to it and it is the issuer of a counteroffer. Since the FRAND objection does not in itself lead to a limitation of the information and accounting claims, this must be asserted separately by way of counterclaim.

The Plaintiff is of the opinion that the counterclaim is unfounded. It is not evident why the Plaintiff should be liable for the conduct of Advance. Nor is it comprehensible on

what grounds the Defendant could assert a claim for damages to which its parent company is entitled. In any case, the Plaintiff had made several offers on FRAND terms, so that the claim was unfounded. The claims for the provision of information and the rendering of accounts remain unrestricted, notwithstanding the FRAND objection. They had not been partially fulfilled.

The Defendant is of the opinion that the patent in suit will prove not to be legally valid in the decision on the nullity action pending before the Federal Patent Court. It did not validly claim the priority of the two prior applications because they did not disclose a division of slices into independent and dependent slice segments. Therefore, Working Draft 9 on the HEVC standard published on December 18, 2012 (Exhibit B 5) would be contrary to the teaching of the patent in suit in terms of novelty.

For further details of the facts and the dispute, reference is made to the pleadings exchanged between the parties and to the documents on file.

### **Reasons of the Decision:**

The admissible action is currently only partially successful on the merits. The admissible counterclaim is well-founded.

#### **A.**

The proceedings were not to be stayed pursuant to Article 29 (1) of the Brussels Regulation (Regulation (EU) 1215/2012).

According to this provision, if actions concerning the same claim between the same parties are brought before courts of different Member States, the court seised later shall, without prejudice to Article 31(2) of the Regulation, stay its proceedings of its own motion until the jurisdiction of the court first seised is established. Unlike Art. 30

of the Regulation, Art. 29(1) of the Regulation does not provide for any discretionary power to stay the proceedings ("shall stay ... of its own motion"), with the consequence that the stay of the subsequently instituted proceedings is mandatory if the requirements of the provision are met. In addition to the identity of the parties, Article 29 (1) of the Regulation also requires the identity of the subject-matter of the proceedings in both sets of proceedings.

In principle, the terms used in Article 29 of the Regulation to describe *lis pendens* are to be interpreted autonomously (Gottwald in MüKo, Commentary on the ZPO, Brussels Ia Regulation Art. 29, para. 9 with reference to ECJ, ECJ 1987, 4861 - Gubisch vs. Palumbo). The ECJ interprets the term "same claim" broadly, since it is the purpose of the provision of Art. 29 of the Brussels Ia Regulation to avoid parallel proceedings before courts of different Contracting States of the Community in the interest of an orderly administration of justice, since otherwise there is a risk of conflicting decisions. It follows that (patent) infringement proceedings directed to injunctive relief and/or damages and a negative declaratory action seeking a declaration of non-infringement of the property right encompassed by the action for performance are regularly to be regarded as the same claim within the meaning of Art. 29 of the Brussels Ia Regulation and therefore the infringement proceedings, which are usually initiated later, are to be suspended until a decision on jurisdiction in the declaratory action has been reached (on the so-called torpedo cases: Kühnen in Handbook of Patent Infringement, 13th edition 2021, chapter E., para. 102). However, for the question whether two actions brought between the same parties before courts of different contracting states have the same subject matter, only the claims of the respective Plaintiff and not also the objections raised by the Defendant are to be taken into account (ECJ NJW 2003, 2596, para. 32 - Ganter vs. Basch). This follows from the fact that Art. 29 of the Brussels Ia Regulation is linked to the time of the pendency of the action, at which only the respective claims, but not the defenses of the Defendant, are established. This also applies in particular to cases involving SEPs, since the so-called FRAND-Einwand (antitrust objection) is a defense raised by the alleged patent infringer in the course of the proceedings (cf. Kühnen, loc. cit., Chapter E., para. 241f.).

On the basis of these principles, the proceedings here were not to be stayed pursuant to Art. 29 of the Brussels Ia Regulation, since there are already no preliminary

proceedings. The proceedings in England, which were still pending at the time the action was filed, have in the meantime been concluded in the second instance, with the courts there declaring themselves without jurisdiction. The proceedings before the Rechtbank Den Haag comprising a negative declaratory action by the Defendant and its parent company against HEVC were not initiated until July 24, 2020, and thus after the action here was filed on July 17, 2020. Therefore, the temporal requirements of Art. 29 of the Brussels Ia Regulation are already lacking.

For the aforementioned reasons, a stay pursuant to Section 148 of the Code of Civil Procedure is also out of the question in the present case.

## **B.**

The action was only partially upheld.

The challenged embodiments make use of the teaching of the patent in suit and the Plaintiff is therefore in principle entitled to the asserted claims for injunctive relief, information and invoicing, recall, removal from the distribution channels, destruction as well as a determination of the liability for damages on the merits pursuant to Sections 139 et seqq. of the Patent Act. However, these are currently partially unenforceable in view of the objection to antitrust law successfully raised by the Defendant.

## **I.**

The patent in suit relates to the coding of pictures with low delay, in particular with a view to coding according to the HEVC standard.

From the development of the HEVC standard, slices, entropy slices (formerly light weight slices) and WPP were known as tools for parallelization at the priority date, as the patent in suit introduces in paragraph [0002].

As the patent in suit further states in paragraph [0003], picture-level partitioning for parallelization of video encoders and decoders has several advantages over other approaches. In previous video codecs, such as H.264/AVC, frame-level partitioning was only possible with uniform slices at a high cost in terms of coding efficiency. For scal-



able parallel H.264/AVC decoding, it is necessary to combine macroblock plane parallelism for picture reconstruction and frame plane parallelism for entropy decoding. However, this solution approach provides limited reduction in frame latency at high memory utilization. To overcome these limitations, new picture partitioning strategies have been incorporated into the HEVC codec. The reference software version (HM-6) includes four different solution approaches; regular or normal slices, entropy slices, wavefront parallel processing (WPP) partial streams, and tiles. These picture partitions typically have a set of Largest Coding Units (LCU) or, synonymously, Coding Tree Units (CTU) as defined in HEVC, or even a subset of them.

The patent in suit criticizes this known technique in paragraphs [0004] et seq. that normal slices as known from H.264/AVC break the entropy coding and the prediction coding, whereas entropy slices allowed exceeding slice boundaries. In paragraph [0007], the patent in suit then refers to the WPP technique, which can help reduce coding losses.

As the patent in suit further explains in paragraphs [0010] et seq., more partitions generally lead to higher compression losses. However, with WPP, the loss propagation is not as high and therefore the number of picture partitions can even be fixed at one per line. This also leads to several advantages. First, bitstream causality is guaranteed for WPP. Second, decoder implementations can assume that a certain amount of parallelism is available, which also increases with resolution. Finally, none of the context selection and prediction dependencies need to be broken when decoding in wavefront order, resulting in relatively low coding losses. However, so far, all parallel decoding in transform-based approaches are not able to achieve high compression efficiency in combination with keeping the delay low. This is also true for the WPP concept. Slices are the smallest transport units in the coding pipeline and multiple WPP substreams still have to be transported serially.

Against the background of this prior art, the patent in suit formulates it in paragraph [0013] as a (technical) task to provide a picture coding concept that enables parallel decoding, for example according to wavefront parallel processing, with increased efficiency, such as with a further reduction of the end-to-end delay or improvement of the coding efficiency by reducing the additional coding effort that has to be spent.

To solve this task, the patent in suit proposes in claim 1 an apparatus and in claim 15 a method having the following features:

#### Claim 1

- 1.1. A decoder for reconstructing a picture (10) from a datastream (12) into which the picture is encoded in units of slices (14) into which the picture (10) is partitioned,
- 1.2. wherein the decoder is configured to decode the slices (14) from the datastream (12) in accordance with a slice order (16), and
- 1.3. the decoder is responsive to a syntax element portion (18) within a current slice of the slices, so as to decode the current slice in accordance with one of at least two modes (20, 22), and
  - 1.3.1. in accordance with a first (20) of the at least two modes, decode the current slice from the datastream (12) using context adaptive entropy decoding (24) including a derivation of contexts across slice boundaries, a continuous update of symbol probabilities of the contexts and an initialization (38, 40) of the symbol probabilities depending on saved states of symbol probabilities of a previously decoded slice, and predictive decoding across the slice boundaries; and
  - 1.3.2. in accordance with a second (22) of the at least two modes, decode the current slice from the datastream (12) using context adaptive entropy decoding with restricting the derivation of the contexts so as to not cross the slice boundaries, a continuous update of symbol probabilities of the contexts and an initialization of the symbol probabilities independent on any previously decoded slice, and predictive decoding with restricting the predictive decoding so as to not cross the slice boundaries; and
- 1.4. wherein the picture (10) is partitioned into coding blocks (32) arranged in rows and columns and having a raster scan order (36) defined among each other, and

- 1.5. the decoder is configured to associate each slice (14) with a continuous subset of the coding blocks (32) in the raster scan order (36) so that the subsets follow each other along the raster scan order (36) in accordance with the slice order, and
- 1.6. wherein the decoder is configured to save symbol probabilities as obtained in context adaptive entropy decoding the previously decoded slice up to a second coding block (32) in a row according to the raster scan order (36), and
  - 1.6.1. in initializing the symbol probabilities for the context adaptive entropy decoding of the current slice in accordance with the first mode, check as to whether a first coding block of the continuous subset of coding blocks (32) associated with the current slice is a first coding block (32) in a row according to the raster scan order, and,
  - 1.6.2. if so, initialize (40) the symbol probabilities for the context adaptive entropy decoding of the current slice depending on the saved symbol probabilities as obtained in the context adaptive entropy decoding of the previously decoded slice up to a second coding block in a row according to the raster scan order (36), and
  - 1.6.3. if not, initialize (38) the symbol probabilities for the context adaptive entropy decoding of the current slice depending on symbol probabilities as obtained in the context adaptive entropy decoding the previously decoded slice up to the end of the previously decoded slice.

#### Claim 15

- 15.1. A method of reconstructing a picture (10) from a datastream (12) into which the picture is coded in units of slices (14) into which the picture (10) is partitioned,
- 15.2. wherein the method comprises decoding the slices (14) from the datastream (12) in accordance with a slice order (16), and
- 15.3. the method is responsive to a syntax element portion (18) within a current slice of the slices, so as to decode the current slice in accordance with one of at least two modes (20, 22), wherein
  - 15.3.1. in accordance with a first (20) of the at least two modes, the current slice is decoded from the datastream (12) using context adaptive entropy decoding (24) including a derivation of contexts across slice boundaries, a continuous update of symbol probabilities of the contexts and an initialization (38, 40) of the symbol probabilities depending on saved states of symbol probabilities of a previously decoded slice, and predictive decoding across the slice boundaries; and

- 15.3.2. in accordance with a second (22) of the at least two modes, the current slice is decoded from the datastream (12) using context adaptive entropy decoding with restricting the derivation of the contexts so as to not cross the slice boundaries, a continuous update of symbol probabilities of the contexts and an initialization of the symbol probabilities independent on any previously decoded slice, and predictive decoding with restricting the predictive decoding so as to not cross the slice boundaries,
- 15.4. wherein the picture (10) is partitioned into coding blocks (32) arranged in rows and columns and having a raster scan order (36) defined between among each other, and
- 15.5. the method comprises associating each slice (14) to a continuous subset of the coding blocks (32) in the raster scan order (36) so that the subsets follow each other along the raster scan order (36) in accordance with the slice order, and
- 15.6. wherein the method comprises saving symbol probabilities as obtained in context adaptive entropy decoding the previously decoded slice up to a second coding block (32) in a row in accordance with the raster scan order (36), and
  - 15.6.1. in initializing the symbol probabilities for the context adaptive entropy decoding of the current slice in accordance with the first mode, checking as to whether a first coding block of the continuous subset of coding blocks (32) associated with the current slice is a first coding block (32) in a row in accordance with the raster scan order, and,
  - 15.6.2. if so, initializing (40) the symbol probabilities for context adaptive entropy decoding of the current slice depending on the saved symbol probabilities as obtained in context adaptive entropy decoding the previously decoded slice up to a second coding block in a row in accordance with the raster scan order (36), and
  - 15.6.3. if not, initializing (38) the symbol probabilities for the context adaptive entropy decoding of the current slice depending on symbol probabilities as obtained in context adaptive entropy decoding the previously decoded slice up to the end of the previously decoded slice.

## II.

With regard to the two asserted claims 1 and 15, which both relate to the decoding side, the parties dispute solely about the technical understanding of the terms slice and

slice boundaries. The following explanations are given with reference to device claim 1, but also apply in substance to method claim 15.

## 1.

Device claim 1 provides protection for a decoder suitable for reconstructing a picture from a datastream in which the picture is encoded in units of slices (in the following, due to the authoritative nature of the English application language, only the term slice is used) into which the picture is partitioned (feature 1.1).

Features 1.2, 1.4 and 1.5 then refer to one of the basic principles of video (de-)encoding, the division of a picture into blocks and slices. One of the decisive measures in encoding is the division of the pictures to be encoded into smaller units (blocks), the permissible form and size of which can vary depending on the standard (in the H.264/AVC standard, this is referred to as macroblocks, and in the HEVC standard, as coding tree units). In the context of further coding, prediction, which is also already known from the older H.264/AVC standard, represents a possibility to reduce the data volume. In this process, the matches and similarities of individual frames of a video sequence or their blocks/slices are used so that not all pixels of a frame or their values have to be transmitted completely. While so-called intra-prediction exploits similarities of blocks within a picture for predicting other areas of the picture, inter-prediction concerns similarities between different, temporally consecutive pictures. Another measure in coding is the so-called (frequency) transformation, in which the locations of the individual pixels (spatial frequency) are converted so that they are easier to code and transmit. In this process, the original data values become the so-called transformation coefficients. Quantization is another measure to increase efficiency, in which the values from the transformation matrix are rounded so that fewer bits need to be stored and/or transmitted. Quantization, however, leads to losses in quality, since rounding

and the associated rounding errors can cause losses. Finally, the rounded transformation coefficients are ordered as part of the so-called entropy coding in such a way that the non-zero values are at the front and the values equal to zero are at the back, since this means that fewer bits need to be transmitted. The HEVC standard also makes use of the fact that the human eye is less able to spatially resolve color perception than brightness differences. For this reason, coding is not done in the RGB color space, but in the so-called YCrCb color space, where the first component Y (= luma component) stands for the brightness of a pixel and the other two components (= chroma components) for the deviation of the color from an achromatic gray in the direction of red and blue. Because of the poorer color perception of the human eye, the chroma components are also represented with only a quarter of the sampling values of the luma component.

The basic concept of packet-based transmission of encoded video data inevitably leads to undesired delays (so-called "end-to-end delay"), since the sender side has to encode and packetize larger amounts of data and the receiver side may have to wait until all or all of the required data packets have reached it before decoding the video data. Therefore, the division of a picture into slices ensures that the decoder does not have to wait until all blocks of a (whole) picture have reached it, but can start entropy and prediction decoding of a part of the picture already when all blocks of a slice have been transmitted. The division of a picture into too many or too small slices, however, is opposed by the fact that there may then be too little information available for (de-)coding to be able to make a sufficiently accurate prediction of the data omitted for the purpose of compression. For the prediction, it is therefore essential that a sufficient amount of data is available from which the color and brightness values of the respective block can then be inferred.

In this respect, feature group 1.3 refers to the actual highlight of the invention, which provides for the possibility of using at least two modes according to which the slice(s) currently to be decoded can be decoded. The second mode, described in more detail by feature 1.3.2, represents the mode known at the priority time, according to which

only those blocks belonging to the same slice may be used for entropy and prediction (de)coding. Since only blocks within a slice and not also blocks of another (neighboring) slice may be used, this also means that the boundaries of the slice (slice boundaries) are not broken by the (de)coding. This mode brings the aforementioned disadvantage that a balance must be found between the end-to-end delay and the compression rate. In contrast, the mode disclosed by feature 1.3.1 provides that values of another slice or slice segment may also be used, i.e. the boundaries between the slices are broken. This has the advantage that, regardless of the size of the slices, there are sufficient values for successful entropy and prediction (de)coding. In this respect, the patent in suit distinguishes between independent slices or slice segments and dependent slices or slice segments, whereby dependent slices are only relevant for the new first mode.

Finally, feature group 1.6 relates to a further aspect of the present invention, namely the initialization of the so-called Wavefront Parallel Processing (WPP) required for parallel coding or decoding, which, however, is irrelevant to the present dispute.

### **1.1.**

Contrary to the Defendant's understanding, the patent in suit does not only understand a slice as a continuous sequence of picture blocks that are combined into such a slice for the purpose of further processing. Building on this conventional understanding of a slice, as used in particular in the predecessor standards MPEG-1, MPEG-2 and H.264/AVC, the patent in suit also understands an (in)dependent slice to be an (in)dependent slice segment, i.e. a continuous sequence of picture blocks within a slice.

There are no indications for the limited understanding of the Defendant from the wording of the claims, which, in particular with regard to the two modes (feature group 1.3), always speaks only of slice or slice boundaries. The relevant expert in the field of video (de)coding associates the term slice with a subunit of a picture which consists of a

plurality of pixels. These pixels are combined into blocks of a predetermined size (e.g. macroblocks or coding tree units), and the blocks are then combined into slices in a row- and column-oriented manner. This results not least also from paragraph [0004] of the patent in suit (all paragraphs without specification are such of the patent in suit), where is stated:

*"Regular or normal slices (as defined in H.264 [1]) have the largest coding penalty..."*

*"Regular or normal slices (as defined in H.264 [1]) have the largest coding losses..."*

The patent in suit expresses here that it builds on the basic technical framework of the previously known video (de)coding standards and to that extent also takes into account the previously known terminology. Accordingly, the referred figure 1 of the patent in suit also shows regular slices comprising a series of macroblocks. The skilled person therefore understands a slice as a partial section/slice of a whole, whereby it is not excluded that this partial slice can be subdivided into further partial slices/segments.

Nothing else follows from the paragraph [0044] referred to by the Defendant, which states:

*"slice: An integer number of treeblocks ordered consecutively in the raster scan. The division of each picture into slices is a partitioning. The treeblock addresses are derived from the first treeblock address in a slice (as represented in the slice header)."*

*„Stück (slice): Eine Ganzzahl von Baumblöcken, die in der Rasterabtastung aufeinanderfolgend geordnet sind. Die Unterteilung jedes Bilds in Stücke ist eine Partitionierung. Die Baumblockadressen werden von der ersten Baumblockadresse in einem Stück abgeleitet (wie es in dem Stückanfangsblock dargestellt ist).“*

Finally, the skilled person can also take from Figure 9 of the patent in suit, reproduced below in reduced form, a picture (reference numeral 898) which consists of 11 x 9 coding tree blocks (918) which are divided into two slices (900a, b):



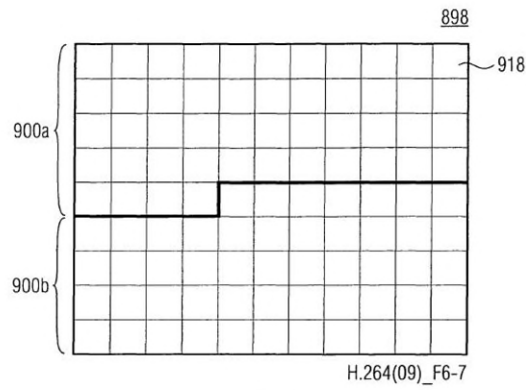

FIG 9

The skilled person also takes from the above figure the slice boundary (thick black line) which separates the two slices and which was not allowed to be broken within the framework of conventional coding.

That the patent in suit does not stop at the conventional meaning of the term slice and that its teaching is therefore not limited solely to breaking down the boundaries between conventional slices, but also encompasses a further subdivision of a slice into slice segments, is also explicitly apparent from the embodiment example of Figure 27 reproduced in reduced form below, as well as the associated description of paragraphs [00154] et seq.:

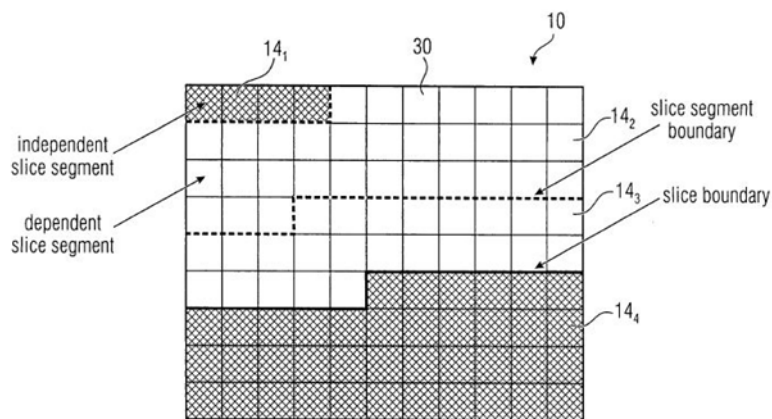

FIG 27

In this regard, the patent in suit states in paragraphs [0154] et seq:

„[0154] It is the just-mentioned dependency which leads, in the below outlined example, to a slightly different wording: slices are defined as unit portions of a picture at which slice header syntax is individually settable. Accordingly, slices are composed of one - using the nomenclature above - independent/regular/normal slice, now called independent slice segment and no, one or more - using the nomenclature above - dependent slices, now called dependent slice segments.

[0155] Fig. 27, for example, shows a picture to be partitioned into two slices, one formed by slice segments 14<sub>1</sub> to 14<sub>3</sub> and the other solely formed by slice segment 14<sub>4</sub>. The indices 1 to 4 show the slice order in coding order. [...]

[0156] The definitions could be as follows:

**dependent slice segment:** A slice segment for which the values of some syntax elements of the slice segment header are inferred from the values for the preceding independent slice segment in decoding order - formerly, in the above embodiments - called a dependent slice.

**independent slice segment:** A slice segment for which the values of the syntax elements of the slice segment header are not inferred from the values for a preceding slice segment - formerly, in the above embodiments - called a normal slice.

**slice:** An integer number of coding tree units contained in one independent slice segment and all subsequent dependent slice segments (if any) that precede the next independent slice segment (if any) within the same access unit/picture.

[...]

**slice segment:** An integer number of coding tree units ordered consecutively in the tile scan and contained in a single NAL unit; the division of each picture into slice segments is a partitioning.”

„[0154] Es ist die eben erwähnte Abhängigkeit, die bei dem nachfolgend aufgeführten Beispiel zu einer etwas anderen Formulierung führt: Stücke sind als Einheitsabschnitte eines Bilds definiert, an denen die Stückanfangsblocksyntax individuell einstellbar ist. Dementsprechend sind Stücke aus einem - unter Verwendung der obigen Nomenklatur - unabhängigen/regulären/normalen Stück, das jetzt als unabhängiges Stücksegment bezeichnet wird, und keinem, einem oder mehreren - unter Verwendung der obigen Nomenklatur - abhängigen Stücken, die jetzt als abhängige Stücksegmente bezeichnet werden, zusammengesetzt.

[0155] Fig. 27 zeigt beispielsweise ein Bild, das in zwei Stücke zu partitionieren ist, eines davon gebildet durch Stücksegmente 14<sub>1</sub> bis 14<sub>3</sub> und das andere lediglich gebildet durch das Stücksegment 14<sub>4</sub>. Die Indices 1 bis 4 zeigen die Stückreihenfolge in der Codierreihenfolge. [...]

[0156] Die Definitionen könnten wie folgt sein:

**dependent slice segment** (abhängiges Stücksegment): Ein Stücksegment für das die Werte einiger Syntaxelemente des Stücksegmentanfängsblocks abgeleitet werden von den Werten für das vorhergehende unabhängige Stücksegment in Decodierreihenfolge - früher in den obigen Ausführungsbeispielen - als abhängiges Stück bezeichnet.

**independent slice segment** (unabhängiges Stücksegment): Ein Stücksegment, für das die Werte der Syntaxelemente des Stücksegmentanfängsblocks nicht von den Werten für ein vorhergehendes Stücksegment abgeleitet werden - früher bei den obigen Ausführungsbeispielen - als ein normales Stück bezeichnet.

**slice** (Stück): Eine Ganzzahl von Codierbaumeinheiten, die in einem unabhängigen Stücksegment enthalten sind und alle nachfolgenden abhängigen Stücksegmente (vorhanden), die dem nächsten unabhängigen Stücksegment (falls vorhanden) innerhalb der/dem gleichen Zugriffseinheit/Bild vorausgehen.

**slice segment** (Stücksegment): Eine Ganzzahl von Codierbaumeinheiten, die nacheinander in der Kachelabtastung geordnet sind und in einer einzigen NAL-Einheit enthalten sind; die Unterteilung jedes Bilds in Stücksegmente ist eine Partitionierung."

The skilled person can see from these passages that the patent in suit uses a further term, that of the (un)dependent slice segment, which is intended to form part of a superordinate slice. Further, the skilled person recognizes from this embodiment that the teaching of the patent in suit, the provision of dependent slices and thus a breaking of the slice boundaries in the context of entropy and prediction (de)coding, can also be applied in cases where a slice is divided into several dependent slice segments, whereby the (de)coding can also break the slice segment boundaries (dashed black line). That the introduction of the term slice segment is an insignificant change of the nomenclature for the scope of protection is explicitly clear to the skilled person from the introductory remarks in paragraph [0154], which speaks of a "*slightly different wording*". In other words, this means that the patent in suit uses a different terminology without basing the modified term, here slice segment instead of slice, on a different technical understanding that is distinct from the teaching of the patent in suit.

Finally, the limited understanding of the term slice advocated by the Defendant does not arise even when considering technical-functional aspects. The highlight of the patent in suit, the provision of a (de-)coding mode in which the boundaries between the slices break the coding, is relevant both for cases in which the picture to be (de-)coded was divided into regular slices and for such cases in which the slices were in turn divided into slice segments. This is because in both cases the efficiency of the coding is equally increased, since for the decoding of the dependent slices/slice segments it is possible to fall back in each case on values from other slices/slice segments, which would not have been available after the conventional coding.

## **1.2.**

Based on this understanding of the term slice, the HEVC standard also makes use of feature group 1.3 of device claim 1 in the context of decoding.

First of all, it is undisputed between the parties that the HEVC standard does not provide for breaking the boundaries between conventional slices. Rather, according to the parties' submission, which is consistent in this respect, the slices in the HEVC standard are subdivided into slice segments, whereby a slice can consist either of a single independent slice segment or of one independent and one to several dependent slice segments.

As far as the Defendant states that the teaching of the patent in suit would only concern the coding side, since only the coder would decide which of the two modes he would use, this does not lead out of an infringement. For one thing, it is in accordance with the general rules of coding that decoding is the mirror picture of encoding and therefore, for successful decoding, all encoding steps must be performed - in reverse order. While it is true that it is - as a rule - the coder who decides on an encoding mode, the decoding device must be designed in such a way that it can process all intended encoding modes, since otherwise it cannot be ensured that all videos encoded in conformity with the standard can also be played. Moreover, it cannot be inferred from

claim 1 either that any selection decision of the decoder device is important. Rather, the decoder is to respond to information in the syntax element in order to be able to decode the current slice on the basis of one of the two modes. Consequently, it should only react, but not make an active selection decision. Last but not least, the HEVC standard also describes the decoding process alone, as can be seen in sections 3.44 and 3.51 of the HEVC standard.

The Plaintiff has also explained in a manner comprehensible to the Board that the syntax element "dependent\_slice\_segment\_flag" provided in the header of a slice segment, which indicates an independent slice segment if the value is "0" and a dependent slice segment if the value is "1", is significant for the decoder. Depending on whether it is a dependent or an independent slice segment, the decoder sets the variable "SliceAddrRs" to a new value (for independent slice segments) or to the address of the previous segment (dependent slice segment), cf. section 7.4.7.1 of the HEVC standard. According to the availability test of section 6.4.1 of the HEVC standard, the value of the variable "SliceAddrRs" is then significant for whether or not a neighboring block is available for decoding the current block. Since the slice segments of a slice always have the same address, the values of neighbor blocks of another slice segment of the same slice are also available for decoding a block of a dependent slice segment. Therefore, in this case, the boundaries between the two slice segments are broken for entropy and prediction decoding.

### **1.3.**

Based on the standard essentiality of the patent in suit, it is thus also established that the challenged embodiments directly implement the device claim, since the Defendant has not disputed that the challenged embodiments decode videos encoded according to the HEVC standard and can thus correctly play back corresponding movies.

## **2.**

In view of the explanations regarding device claim 1, it is also clear that the challenged embodiments are essential elements within the meaning of Sec. 10 Patent Act and therefore the asserted process claim 15 is also infringed.

The offer and distribution of the challenged embodiments constitute an indirect infringement of the patent in suit in the form of patent claim 15 pursuant to Sec. 10 (1) Patent Act.

The challenged embodiments are a means within the meaning of Sec. 10 (1) Patent Act that is objectively suitable for the application of the process protected by claim 3 in suit. For the HEVC standard compatibility of a device presupposes - as shown - the suitability for the application of the protected method. The challenged embodiments are such HEVC standard compatible devices.

Thus, the challenged embodiments also relate to an essential element of the invention. This is the case if the means is suitable to functionally cooperate with an essential element of the invention, namely one mentioned in the patent claim, in such a way that the idea of the invention is realized (BGH, GRUR 2004, 758, 760 - Flügelradzähler; GRUR 2005, 848 - Antriebsscheibenaufzug; GRUR 2006, 570 - extracoronales Geschiebe). In the case in dispute, the decoding method according to the patent in suit can be put into effect by the challenged embodiments because the challenged embodiments are programmed or set up accordingly.

The Defendant indisputably offers and supplies the challenged embodiments in Germany for use of the invention. Thereby, it is obvious on the basis of the circumstances that the challenged embodiments are suitable and intended to be used for the use of the invention. In this respect, it is decisive whether at the time of the offer or delivery, according to the entire circumstances of the case, the threatened patent infringement was so clearly recognizable from the point of view of the offeror or supplier that an offer or delivery is to be equated with knowingly endangering the patent (BGH, GRUR 2007, 679 - Haubenstretchautomat). It is sufficient if, from the perspective of the third party,

when viewed objectively, there is a sufficiently certain expectation under the circumstances that the customer will designate the means offered or supplied for patent-infringing use (BGH, GRUR 2006, 839 - Deckenheizung).

In the case in dispute, the establishment of HEVC standard compatibility is a consequence of the targeted and purposeful implementation by the Defendant. Playing HEVC video content is only possible in a patent-infringing manner. The fact that the Defendant subjectively expects that it is practically certain that users will play HEVC videos is already obvious because it opens up this function to users in a targeted and purposeful manner by providing the corresponding compatibility. From the perspective of a third party, it is also practically certain that users will also play HEVC content. In order to determine this factual characteristic, experience from everyday life can be used (BGH, GRUR 2005, 848, 851 - Antriebsscheibenaufzug). According to this, the playing of video content on technical devices is nowadays one of the core functions of modern devices, which, according to general life experience, is used by practically everyone. The use of the patented method by the customers of the challenged embodiment is certainly to be expected.

### III.

The claim seeking an order against the Defendant to cease and desist, destroy and recall from the distribution channels is nevertheless unsuccessful because the Defendant's objection to compulsory licensing under antitrust law currently prevails (Article 102 TFEU). The objection raised is to be assessed on the basis of the principles as set out by the European Court of Justice in the case "Huawei Technologies/ZTE" (ECJ, judgment of July 16, 2015 - C-170/13, GRUR 2015, 764 = ECLI:EU:C:2015:477 as amended by the rectification order of December 15, 2015, ECLI:EU:C:2015:817; hereinafter: ECJ judgment) in the interpretation of the prohibition of abuse under antitrust law pursuant to Art. Article 102 TFEU and have been elaborated in more detail by the Federal Court of Justice in the decisions FRAND-Einwand (BGH, judgment of May 5, 2020 - KZR 36/17, GRUR 2020, 961; hereinafter: FRAND I) and FRAND-Einwand II

(BGH, judgment of November 24, 2020 - KZR 35/17, GRUR 2021, 585; hereinafter: FRAND II).

The Board is convinced that the Defendant has shown that the Plaintiff is abusing its dominant position (see 1.) (see 2.).

## 1.

The Plaintiff holds a dominant position within the meaning of Article 102 TFEU.

### 1.1.

"Market dominance" means the position of economic power which enables an undertaking to prevent effective competition on the relevant market (in terms of time, space and products) and to behave to an appreciable extent independently vis-à-vis its competitors, customers and consumers (ECJ [78] ECR 207, para. 65 et seq. - United Brands; ECJ [79] ECR 461, para. 38 et seq. - Hoffmann-La Roche; FRAND I, para. 55; Kühnen, loc. cit., Chapter E, para. 231 et seq.).

The necessary exact delineation of the (product and geographic) market on which companies compete can be carried out by means of the so-called demand market concept (cf. in more detail (Paschke/Berlit/Meyer/Kröner, Hamburger Kommentar Gesamtes Medienrecht, 2nd part: 5th chapter, para. 6 et seq.). The competitive forces to which the companies in question are subject must be identified. Furthermore, those companies are determined which are actually in a position to set barriers to the behavior of the companies involved and prevent a withdrawal of competitive pressure. It must be clarified which products or services are functionally interchangeable with each other from the point of view of the demanders. What cannot be substituted by other products or services from the point of view of the demanders on the basis of their respective characteristics, prices and intended uses is assigned to the same product market. A combination of several factors must be taken into account (such as market share, company structure, competitive situation, behavior on the market, but in principle not price; see Paschke/Berlit/Meyer/Kröner, loc. cit., para. 11). Individual factors do not necessarily have to be decisive in themselves. In this respect, the territory of the Federal



Republic of Germany - like every member state - also constitutes a substantial part of the common market (see ECJ [1983] ECR 3461, para. 103 - Michelin/Komm).

In connection with the prohibition rights from a patent asserted here, the delimitation described must be made with regard to the licensing market (cf. Kühnen, loc. cit, Chapter E, para. 230): The supplier is the patent proprietor, who alone is able to grant a license for the respective patent, which enables potential suppliers of this product to put it on the market (cf. FRAND I, para. 57); the customer is the user interested in the patented technology (e.g. the manufacturer of patented products). In principle, each patent leads to a separate relevant product market, unless in the individual case an equivalent technology - from the point of view of the demanders - is available for the same technical problem.

The ownership of a standard essential patent ("SEP") as such does not yet establish a sufficient condition for market dominance and, in particular, does not establish a rebuttable presumption that the SEP owner can prevent effective competition precisely because the SEP must be used due to the standard essentiality in order to be able to generate products compatible with the standard (LG Düsseldorf, judgment of July 13, 2017, Ref. 4a O 16/16, BeckRS 2017, 129534; Kühnen, loc. cit., Chapter E, para. 231; Müller, GRUR 2012, 686; a.A. seemingly Opinion of Advocate General Wathelet of November 20, 2014 in Case C-170/13 para. 57 = BeckRS 2014, 82403; ECJ judgment, para. 43 left the question open because the market dominance in the individual case submitted was undisputed and therefore not the subject of the questions referred). It is therefore necessary, with respect to each individual patent included in the standard, to assess its competitive significance for the downstream product market based on the circumstances of the individual case (Kühnen, loc. cit, Chapter E, para. 231 et seq.): If it is found in this respect that the use of the respective SEP virtually constitutes a market entry requirement, a dominant position is to be affirmed even if the technical effect resulting from the respective SEP does not decisively influence market participation, but access-relevant functions could not be used for technical reasons, so that general

interoperability/compatibility would no longer be ensured (cf. in particular OLG Düsseldorf, GRUR 2017, 1219 - Mobiles Kommunikationssystem). The same applies if a competitive offer would not be possible without a license on the SEP in question (e.g. because there is only a niche market for non-patented products).

In accordance with general principles, the Defendant bears the burden of presentation and proof with regard to market dominance (OLG Düsseldorf, loc. cit. - Mobiles Kommunikationssystem). The Defendant is required to provide sufficiently specific facts to permit a judicial review of whether or not a dominant position exists on the relevant geographic and product market.

## **1.2.**

In the present case, the Defendant did not initially submit any facts of its own to prove a dominant position of the Plaintiff, but referred to the findings of the Board in the judgments in the series of lawsuits of the Plaintiff and other licensors against XXX, for example on file number 4c O 44/18. Because the Board had found a dominant position of the Plaintiff therein, this applies here in the same way. This submission is (exceptionally) sufficient in view of the circumstances of this legal dispute - as well as the pending parallel proceedings. To the extent that the Plaintiff criticizes this, it cannot prevail with this criticism. By referring to the parallel proceedings against XXX, which had already been heard and decided before the Board, it was sufficiently clear to the Plaintiff what the Defendant was basing its argument about the dominant position on. The fact that a different assessment could apply to the property right at issue in comparison to the patents in suit of the concluded series of proceedings is neither evident nor asserted by the Plaintiff in this respect. Consequently, there is no reason for the board to assess the economic position of the Plaintiff differently here. Moreover, in the present proceedings, it is the Plaintiff itself that repeatedly refers to the decision in the proceedings 4c O 44/18 with regard to certain aspects and wants to refer to it. However, it is not evident why this should not also be the case only for the question of the dominant market position.

With regard to the market for the HEVC standard to be licensed, the Plaintiff therefore holds a dominant position because, mediated via Advance as pool administrator, it can decide on the granting of licenses with regard to the property rights relevant to the standard. As a result, it is in a position to prevent competition on the downstream market, which consists of all HEVC-capable terminal equipment. Although the HEVC standard does not influence the downstream product market in the sense of a market entry requirement, since in principle end products can also be marketed without this common standard, the equipment of the end devices with this video standard is nevertheless a significant factor. This is because without its provision, the products (TVs, set-top boxes, tablets, etc.) would indeed be uncompetitive because, in the absence of (de)encoding devices, it would be practically unsuitable for playing videos and for the average user, who considers this playback option to be an important function in the form of a "must have". Indeed, there is no other standard currently available that could replace the HEVC standard at an equally reduced bit rate, so licensing from Advance or the Plaintiff itself would not matter. Only this standard is capable of efficiently compressing large amounts of data in order to make them available to the end user in good quality over the available bandwidth. In this respect, it is common practice on the part of the end device manufacturers to equip the devices in such a way that all common standards are supported and video content can be played back correctly. This is because it is the content provider who selects which standard is used for encoding, and to this extent assumes that its content will be playable on all common devices.

Finally, nothing else follows from the Defendant's own submission, on the basis of which it wants to show (in any case only in connection with the appropriate license fee amount) that the HEVC standard has precisely not become established and only accounts for a small share of encoded video content. For even after this, it is the case that where content is offered in HEVC encoding, no technically equivalent alternative is available that can transmit the same amount of data using the same bandwidth as HEVC-encoded content. Accordingly, it may be that (currently still) the HEVC market as a whole is smaller than that for H.264/AVC, for example. However, the Plaintiff is dominant in this market, and H.265 technology has no alternative.

In addition, the own advertising statements of the Defendant or XXX refer to the advantages of UHD, for the encoding of which the HEVC standard is preferably used. Furthermore, the Board has no doubts that, for example, video streaming services such as Netflix, Amazon, Disney, etc. have been encoding their content in HEVC for several years (see Annexes ES Cart 45 - 48). Even if these could also be decoded - with a corresponding loss of quality - by other standards, these service providers assume that an increasing number of end devices are capable of decoding UHD/4k content using HEVC. Precisely because of this circumstance, that the service providers decide on the encoding format, there is a need for device manufacturers to offer HEVC-capable devices in order to remain competitive. This is because the trend toward ever better picture quality with simultaneously fast data transmissions continues unabated.

Nothing else follows from the Plaintiff's written statement of November 12, 2021, which has been omitted, with regard to the question of the market-dominant position. According to this statement, too, it is undisputed that HEVC coding is without alternative for DVB-T2 transmissions.

## **2.**

The Plaintiff has not sufficiently complied with its FRAND obligations arising from the prohibition of abuse and discrimination under antitrust law (Art. 102 TFEU). It is abusively exploiting its dominant position in the market.

A market-dominant patent proprietor who has undertaken vis-à-vis a standardization organization to grant licenses on FRAND terms cannot abuse his market power merely by refusing to conclude a corresponding license agreement with an infringer who is willing to obtain a license and by bringing an action against him for injunctive relief, recall and removal of products from the distribution channels or for destruction of infringing products (FRAND I, para. 71). Abuse may also be present if the patent proprietor is to be blamed for not having made sufficient efforts to fulfill the special responsibility associated with the dominant market position and to make it possible for an

infringer who is in principle willing to license to conclude a license agreement on reasonable terms (FRAND II, para. 53). This conduct is not compatible with the infringer's claim that the SEP holder contractually permits him to use the protected technical teaching on FRAND terms (see FRAND II, para. 54).

In both cases, the action is abusive because the infringer willing to license is entitled to have the patent proprietor contractually permit him to use the protected technical teaching on FRAND terms. The abuse of market power thus follows from the refusal of a demanded access to the invention per se or from unreasonable conditions for a demanded access, from which the patent proprietor is not willing to deviate even at the end of negotiations, i.e. the refusal, the refusal to offer the licensee seeking to conclude a license agreement on FRAND terms, as a result of a negotiation process, those fair, reasonable and non-discriminatory contractual terms which the licensee can claim and on which it, for its part, is prepared to conclude with the patent proprietor (cf. FRAND II, para. 54).

When assessing in each individual case whether the enforcement of patent infringement claims is accompanied by such a refusal to license on the part of the dominant patent holder vis-à-vis the infringer and thus appears to be an abuse of the patent holder's market power, it is necessary to consider, on the one hand, the duties of conduct incumbent on the patent holder, which arise originally from antitrust law - and which may be influenced by the license commitment (cf. FRAND I, paras. 73-81; FRAND II, paras. 55 et seq.; OLG Karlsruhe, GRUR 2020, 166, paras. 94-96 - Datenpaketverarbeitung). On the other hand, it must be asked whether the infringer is acting as a bona fide license seeker. In this respect, the infringer must ask to conclude a license agreement on reasonable and non-discriminatory terms (so-called declaration of willingness to license or licensing request), and such a request must not be mere "lip service". A merely verbally expressed request for the grant of a license is not sufficient if the remaining behavior of the declaring party, when viewed objectively, unmistakably testifies that the request for a FRAND license is mere lip service, which is clearly not supported by a serious intention to take a license, but rather serves the

sole purpose of stalling the patent proprietor, delaying his legal prosecution and thus being able to continue the actions using the patent undisturbed (OLG Düsseldorf, decision of July 14, 2021, Case No. I-2 U 13/21).

According to the case law of the ECJ in *Huawei vs. ZTE* (ECJ judgment), which has been further elaborated by the Federal Court of Justice in the FRAND I and FRAND II decisions, the owner of an SEP must inform the alleged infringer (hereinafter: "infringer") of the patent infringement before he asserts his claim for an injunction or recall (Guiding Principles and para. 61 ECJ judgment). Insofar as the infringer is prepared in principle to take a license, the SEP proprietor must submit to him a concrete written offer to license the SEP on fair, reasonable and non-discriminatory terms and conditions, and in doing so must also explain the method of calculating the required royalties (para. 63 ECJ judgment). The infringer must respond to this in good faith and in particular without delaying tactics (para. 65 ECJ judgment). If he does not accept the SEP holder's offer, the infringer must submit a counter-license offer within a short period of time, which complies with the FRAND requirements (para. 66 ECJ judgment). If the SEP holder rejects this counter-offer, the infringer must account for the use of the SEP from that point in time and provide security for the payment of royalties, which also applies to past use (para. 67 ECJ judgment).

In the examination to be carried out in the case in question in accordance with the aforementioned requirements, it can be established at the end of the oral proceedings that the Plaintiff is to be accused of refusing to grant a license in violation of antitrust law.

## **1.1.**

The Plaintiff duly notified the Defendant of the infringement - as required in principle (see ECJ judgment, para. 61; FRAND I, para. 73 et seq.; FRAND II, para. 55).

### **1.1.1**

The infringement notice is intended to draw the infringer's attention to the facts of infringement and also to the possibility and necessity of taking a license, by designating the patent, the type of infringing act and the attacked embodiment; detailed technical or legal explanations of the infringement allegation are not required. Neither an indication of the standard essentiality of a patent nor a comparison of the claim features with the features of the standard is required. This is because the (substantive) requirements for the infringement notice must not be overstretched to such an extent that the patent proprietor is already obliged at this early stage of the dispute to give detailed reasons as to how the individual features of the patent claim are realized and thus to derive his claims from a legal point of view. It is initially the responsibility of the infringer to examine the content of the allegation of infringement (cf. Kühnen, loc.cit., Chapter E, para. 385).

### 1.1.2

In any event, the email from Advance dated January 11, 2018 (Exhibit GRÜ 3) in conjunction with the email dated April 3, 2017 (Exhibit GRÜ 1) provides sufficient infringement notice to Defendant or its XXX parent company XXX.

#### (1)

The parent company of the Defendant was the correct addressee of the infringement notice. Approaching the parent company to conclude a pool license agreement on a technology standard is a conventional procedure. It is not subject to any reservations, in particular, if it can be expected that the infringement notice will be forwarded to the respective subsidiaries, as in this case to the Defendant, which it concerns in the different countries of protection (cf. OLG Karlsruhe, GRUR 2020, 166, para. 111; Kühnen, loc. cit., Chapter E, para. 386).

This is the case here; Advance was entitled to assume that its letter would be forwarded within the group. In this respect, it must also be taken into account that it is the parent company that would enter into a license agreement with Advance with effect for its subsidiaries. It is therefore appropriate to send the infringement notice directly to the parent company.

**(2)**

In the April 2017 email, Advance referred to the HEVC patent pool and made clear that XXX products such as UHD TV and 4K UHD set-top boxes have decoders that make use of the standard technology. For more detailed information on the pool and the licensing program, Advance referred to its website at [www.hevcadvance.com](http://www.hevcadvance.com). At the same time, Advance XXX held out the prospect of being able to take advantage of the ongoing incentive program and thus benefit from fee reductions if licenses are taken up quickly. However, this letter did not contain any reference to a specific patent which Advance considered to be infringed. On this basis, XXX could therefore not yet enter into a technical examination of the allegedly infringed property rights. Even if it had obtained an overview of all standard-essential patents via the website, it would still not have had any concrete indication of which property rights Advance would rely on (possibly also in later court proceedings). However, the infringement notice is intended precisely to counter an information deficit on the part of the infringer, who may not be positively aware of the use of each individual SEP in view of the large number of SEPs comprising the standard (see FRAND II, para. 55; OLG Düsseldorf, GRUR 2017, 1219 - Mobiles Kommunikationssystem with reference to ECJ).

In an email from January 2018, Advance then sent XXX claim charts in which it compared 17 individual patents contained in the HEVC pool to the standard in order to complete the allegation of infringement in this way. From this point on, it was possible for XXX to understand which patent infringement it was accused of.

**1.2.**

In any case, the Defendant or its parent company impliedly requested a license prior to the proceedings and it cannot be established that this was merely lip service, which can be concluded from an assessment of its overall conduct up to the end of the oral proceedings.

**1.2.1.**

With the licensing request addressed to the patent proprietor, the license seeker must express his willingness to conclude a license agreement on FRAND terms (ECJ judgment, para. 63). His serious willingness must be recognizable without having to comply



with certain formal requirements. As a result, it is sufficient to express the willingness to license in a general and informal manner and by conclusive behavior. The decisive factor is that it is unambiguous from the point of view of the patent proprietor (cf. FRAND II, para. 57; OLG Düsseldorf, loc. cit. - Mobiles Kommunikationssystem). The licensor must be certain - during the entire negotiation period - that the licensee is seriously interested in taking the license. Before expressing such a license request, the user must in any case be granted a sufficient period of consideration, the length of which may be based on the level of detail of the infringement notice. However, the user is prohibited from intentionally delaying the conclusion of a license agreement by means of delaying tactics. This is incompatible with the user's obligation to participate purposefully in the negotiations (see FRAND I, para. 83).

In terms of content, however, the requirements for the licensing request must not be overstretched. The task of the licensing request is to inform the licensor - as a preliminary question, so to speak - whether the infringer is in principle prepared to accept the license or whether he consistently rejects it (cf. OLG Karlsruhe, GRUR 2020, 166, para. 115 - Datenpaketverarbeitung). This is the essential aspect which is to be expressed by a license request: the user is to commit himself to one or the other approach and (have) adhered to it in the future. This information is already sufficient for the SEP holder, but also necessary to impose the obligations on the SEP holder according to the Huawei/ZTE criteria, in order to be able to submit a license offer in case of the fundamental willingness to license. It is by no means sufficient if the user merely states in response to the infringement notice that he is considering concluding a license agreement, or if he merely begins negotiations on whether to conclude an agreement (see FRAND II, para. 57). Such a reaction does not satisfy the relevant requirements set by the ECJ to express the intention to conclude a license agreement on FRAND terms.

In addition to the clear positioning for or against taking a license, it is not to be expected of the infringer that he already materially deals at this point with individual terms of the license agreement which, in his opinion, could fulfill FRAND criteria and are possibly

even embodied in the counter-offer. Such statements could, moreover, be to his disadvantage if the SEP Holder perceives them as conclusive and unalterable and thus as a lack of willingness to negotiate on the part of the User. In addition, they could be obviously non-FRAND contractual terms and conditions, which the SEP holder does not even have to agree to in the course of contractual negotiations (cf. Kühnen, loc. cit., Chapter E, para. 393). Consequently, an infringer would be denied his willingness to license because of statements regarding the content of the offer, although he was not yet required to make such statements at this usually early stage of the licensing negotiations. If a substantive discussion of FRAND contract terms or even the counteroffer were to take place at the stage of the licensing request, this would contradict the interplay of the Huawei/ZTE procedure established by the ECJ. The licensing request is thus a prerequisite for the submission of the FRAND-compliant license offer, to which the counteroffer must respond. At the moment of the license request, a counteroffer is not yet relevant.

The above does not change the mutual obligations to cooperate in the conclusion of a FRAND license agreement, which can undoubtedly also be inferred from the ECJ judgment, because appropriate conditions for a contractual relationship, in particular an appropriate price, are regularly not objectively fixed, but can only be determined as the result of negotiated market processes. The serious and purposeful participation of the company willing to license in the negotiation of appropriate contractual terms is therefore essential and of decisive importance (see LG Mannheim, judgment of August 18, 2020 - 2 O 34/19 -, juris, para. 159). However, when such reasonable conditions exist is a question of substantive law that concerns the actual content of a FRAND license agreement and about which a user does not have to be and cannot be clear at the moment when he expresses his willingness to license in principle. This is because the SEP holder is regularly in a better position to make a license offer that meets the requirements for equal treatment due to its knowledge of the market. A user is not, or at least not readily, in a position to formulate FRAND conditions on his own initiative (see also FRAND I, para. 75 with reference to ECJ judgment).

Assessing the willingness to license separately from substantive law aspects is also the correct starting point because concrete contractual negotiations can only be meaningfully entered into after the offer has been made. The SEP holder's offer forms the basis for constructive contractual negotiations between the parties because it is not known beforehand which (FRAND) contractual terms and conditions the licensor, who is obliged to provide advance performance in this regard, intends to make the subject matter of the contract. In this respect, this offer may be understood merely as a starting point for a subsequent contract.

According to the above, the question of willingness to license may at most be based on the circumstances and the basic submission of a counteroffer in the course of a negotiation history as well as on the infringer's conduct in general, but no FRAND examination of the content of the contractual clauses may take place.

Just as the counter-offer may not be assessed in the context of the readiness to license, there is no reason to discuss the content of the license offer at the time of the license request and to derive from this reduced requirements for the user's obligations of conduct even if it is obviously un-FRAND. This is because, due to the constitutive succession of Huawei vs. ZTE duties of conduct, the submission of the license offer is only required after the declaration of willingness to license. The only case to be distinguished from this is if, for example, a license offer was made at the same time as the infringement notice. In these cases, however, the submission is super-mandatory, so that the separate declaration of willingness to license is no longer relevant.

In order to base the requirements for willingness to license outlined above on concrete facts, the overall behavior of the licensee during the period of the contract negotiations must be assessed (cf. OLG Düsseldorf, loc. cit., para. 198 - Mobile Communication System). Thus, once a license request has been made, it may be counteracted by subsequent conduct and may lapse again. The (general) willingness to license just described therefore overrides the contract negotiations. If, in a first step, only a general statement by the infringer to take a license is necessary and sufficient, and only at a later point in time, i.e. after the license offer has been made, does the licensee's concrete willingness to take a license become important, this implies that the general willingness must in any case persist permanently - beyond the actual moment when it is

made known. For the licensee, this means that he must henceforth show his willingness to take a license by actively, encouragingly and purposefully participating in the license negotiations. In this context, a generous and rather abstract standard must be applied so that the actual substantive discussion of FRAND-compliant contractual terms is in any case reserved for the examination of the license offer. The focus of the examination of (non-) abusive conduct can thus correctly be placed on concrete substantive aspects, where the fair balance of the interests concerned required by Art. 102 TFEU (cf. ECJ judgment, para. 55) is most likely to have an effect. This weighting of the willingness to license and the FRAND offer prevents the Huawei/ZTE procedure from being too top-heavy, based on overly formal criteria.

### **1.2.2.**

Based on the above explanations, the Board is convinced that XXX was and has remained willing to license after submitting its licensing request. They have expressed this willingness to Advance in a sufficient manner. This applies both to the period before the filing of the action and afterwards; in particular for the period after the filing of the action, the willingness to license has not subsequently ceased.

#### **(1)**

A first contact by Advance took place in April 2017. In an email dated April 3, 2017, Advance presented the HEVC patent pool and its licensing program through its Senior Vice President XXX (see Exhibit GRÜ 1). Subsequently, an exchange between the parties already took place. Then, in December 2017, representatives of XXX and of HEVC Advance (XXX) met in person to discuss the conclusion of a licensing agreement. Although more detailed explanations as well as evidence for this, as well as for the period until then, have not reached the file, it is, however, logical that there must have been corresponding consultations between the parties at least before this meeting. In or as of January 2018 after the submission of 17 claim charts (cf. Annex GRÜ 3) XXX then carried out technical examinations of the designated property rights. XXX informed Advance of this (cf. Exhibit ES-Kart 2, email January 17, 2017). Likewise,

XXX was already at pains in this initial contact to explain delayed feedback (cf. e-mail of March 14, 2018). By doing so, XXX underlines its basic willingness to stay in contact with each other, as in the Board's view such explanations would not be self-evident.

The further e-mail correspondence between the legal representatives of XXX and Advance from spring 2018, which was submitted to the file as Exhibit ES-Kart 3, is also evidence of XXX's willingness to license. It explains that XXX had already unsuccessfully requested Advance to make the license offer available. By now again requesting the submission of a license offer, XXX explicitly makes clear to be ready for licensing. In this respect, it is not necessary to decide whether Advance was justified in assuming, according to its own descriptions, that XXX was not ready for a license until its e-mails of May 7 (note: not submitted) and May 9, 2017. For in any case, a license request expressed only in the e-mail of May 9, 2017 would still be sufficiently temporally related to the transmitted claim charts, also in view of the e-mail exchange in the meantime. In the case of the 17 claim charts sent at the same time, XXX was allowed to make use of a review period for technical investigations, which was also not too long here at just under four months.

It is also not necessary to decide at this point whether the HEVC standard license agreement is usually not sent by Advance to interested licensees, but is downloaded by them directly from the homepage, and whether this possibility would also have been open to XXX, with the consequence that it could have had knowledge of a concrete license offer earlier and of its own accord. Because at the time of the transmission in May 2018, the parties were already in contact to discuss a possible licensing.

Advance, through its claimant representative, moreover, admitted itself in early May 2018, shortly before the license offer was submitted, that there was a prolonged period of not speaking to each other during this initial stage of the negotiations ("it's been a while, since we last spoke [...]"; see Exhibit GRÜ 4). However, the reasons for this are not known.

Following the submission of the license offer by Advance on May 18, 2018, the parties seamlessly maintained their negotiations. Thus, substantive meetings with Advance took place on June 11, November 13 and 14, 2018, which included both technical and economic issues for a license acceptance. Minutes of the discussions were taken following each of these meetings (see Exhibit ES-Kart 1 Minutes of Discussion dated June 11, 2018), which give no indication of a lack of willingness to license on the part of XXX. The email submitted as Exhibit GRÜ 5 is evidence of further substantive disputes between the parties even after the actual meetings. Advance has responded to doubts expressed by XXX ("response to claim charts").

The situation was similar following the November 2018 meetings (see Exhibit ES-Kart 7). In this regard, Advance itself states that the meetings were fundamentally constructive and that the points raised by XXX certainly seemed to indicate that it would be possible to enter into negotiations and conclude a license agreement within a reasonable timeframe; just as Advance has succeeded in doing with the other 200+ licensees. Advance assumed that non-technical discussions would now begin because the technical discussions were deemed to have been successfully completed. Accordingly, the meetings were constructive and there was no indication that they would not be able to resolve the outstanding issues (past payment, royalty amount and dual licensing) in the same way.

From the beginning, the talks between Advance and XXX were characterized by the fact that it could sometimes take several weeks to hear back. None of the parties, however, attributed to such a period of time the significance of only a sluggish willingness to negotiate. Explicitly acknowledged and agreed to such an approach were the parties in the context of their meeting of June 11, 2018, because as documented in the email of July 11, 2018 (Exhibit GRÜ 5), a time window for further steps was agreed upon. Thus, a counteroffer from XXX was to follow in October 2018, i.e., about 4 months later. In light of this timeframe, XXX of Advance also does not express any concerns per se, but only points out that any benefits could be lost. To be sure, there

may have been equally short-term email exchanges over time. However, this is not the usual response time; neither on the part of XXX nor Advance.

The correspondence extending from mid-November to January 2019 (cf. Exhibit ES-Kart 7) culminated in the counteroffer submitted by XXX in mid-January 2019 (cf. Exhibit GRÜ 8), whereby XXX also explained to Advance in each case why the counteroffer had not been submitted as planned already in October 2018. Therein, USD XXX was offered for ongoing license payments and a lump sum of USD XXX for the past. XXX based the determination of its fee amount on the license rates of the HEVC standard of MPEG LA.

Subsequently, as well as after the initiation of the proceedings in the UK, the parties continued to communicate with each other, as the further e-mail correspondence submitted as Exhibit ES-Kart 10 shows. Here, the parties discuss the subject matter of the counteroffer and Advance in particular has various inquiries regarding the branding of the products distributed by XXX.

In February 2019, the parties agreed to hold a telephone call to which lawyers were to be invited (Annex ES-Kart 11). The fact that it was XXX's wish to involve legal representatives in the discussions from then on cannot, however, give rise to any doubts as to the willingness to license. The meetings may lose their informal character as a result; however, the question of willingness to license depends less on the participants in the negotiations and more on the fact that a mutual exchange takes place at all. This, in turn, was the case in the present case even after inclusion of the attorneys.

On April 30, 2019, the negotiating parties together with their XXX attorneys met in XXX. A relevant point of this meeting was the presentation of settlement license agreements and how Advance could provide sufficient transparency to XXX. The minutes of the meeting of April 30, 2019 written by XXX as XXX representative of XXX (Exhibit GRÜ 9\_2), as well as the one of the XXX representatives of Advance XXX (Exhibit ES-Kart 5) illustrate the topics of discussion during the meeting and especially the fact that

progress could be given to the negotiations between the parties by this meeting ("[...] hypothesized that progress in the meeting could be made by addressing two points...").

For the period from about May to October 2020, i.e. for the time since the filing of the lawsuit, XXX has not submitted any more evidence of an exchange with Advance in order to demonstrate its willingness to license, so that one could assume a temporary interruption of the license negotiations. However, this is exactly the period of time during which XXX had mainly bilateral discussions with the Plaintiff as well as with other SEP holders (cf. parallel proceedings before the Board). It is a legitimate interest of a SEP user to obtain contract offers also during already ongoing licensing negotiations with a patent pool, even only covering individual patents, and thus to make a decision on the basis of economic considerations. There are all the less reservations about parallel license negotiations if this procedure is openly communicated to the pool administrator and it is recognizable that the approach to individual SEP holders is not only made for appearances and under pretense of a license interest in order to delay and block the actual license negotiations with the pool. This was the case in the present case. Advance had knowledge of the bilateral license negotiations. Thus, XXX's behavior could not reasonably be understood otherwise than that it continued to strive to take a license and merely had to find out whether several bilateral licenses might be more appropriate than a pool license.

The fact that Advance did not actually evaluate this in such a way follows in any case from the updated license offer transmitted at the end of October/beginning of November 2020 (Exhibit ES-Kart 14 et seq.) as well as already from Advance's reaction at the beginning of October 2020 (cf. Exhibits GRÜ 17\_1) to XXX's request to provide contact data of the licensors (Exhibits GRÜ 13 et seq.). During this time, substantive discussions took place between the parties regarding the contractual terms and conditions of the license fee and dual licensing. The Defendant submitted reciprocal cover letters for the file with the enclosures GRÜ 21 to GRÜ 31, by means of which remaining questions were to be clarified both with XXX and with Advance. The essential subject of the communication was also here the information about products distributed by XXX and their



respective brand marking. In addition, these attachments document that a video conference took place on November 10, 2020 (Attachment GRÜ 29), to which further e-mails were exchanged afterwards (Attachments GRÜ 30, 31). That the correspondence between Advance and XXX was not based on a weekly exchange, but definitely took longer time intervals, is evident from Exhibit GRÜ 30 at the end, wherein XXX in the aforementioned video conference held out the prospect of needing a one-month cooling-off period. At the same time, these email excerpts document that it is repeatedly Advance that lingers on the numbers provided by XXX, asking more and more follow-up questions, without answers to which they felt unable to calculate the amount of fees for Past Sales. In any case, these repeated inquiries and further requests for clarifications are unlikely to have unduly accelerated the course of negotiations, especially since it is evident from the answers that XXX did not know how to respond otherwise either.

To the extent that isolated e-mails, such as the one of December 21, 2020 (Exhibit GRÜ 23), contained statements by Advance such as "[...] We look forward to re-engage in licensing discussions with XXX [...]", they are not to be attributed the meaning that previous negotiations would be regarded as having failed and XXX as not being ready for licensing. In any event, there are insufficient factual circumstances on the basis of which the Board could make this determination. The e-mails do not offer any further indications for this; the known negotiation events likewise little. Directly from this described communication flow, no behavior of XXX is recognizable that could indicate its lack of willingness to license. In particular, XXX's inquiries to Advance, such as the naming of the responsible persons of each licensor for bilateral correspondence (cf. Annexes GRÜ 13, GRÜ 14, GRÜ 15), are not suitable for this purpose. Admittedly, it is likely to be his very wide-ranging request and XXX should be able to make appropriate contact due to his own company size. Nevertheless, it cannot be seen that XXX pursued a delaying tactic with this request; that Advance would have taken this in such a way is also not evident, especially since they transmitted the requested data with e-mail of October 6, 2020 (Exhibit GRÜ 18). Apart from these formulations, it is therefore neither evident nor alleged by the Plaintiff on the basis of objective evidence that it

assumed at that time in each case that license negotiations had already failed, because XXX would have seriously and finally (§ 323 BGB) refused to continue the correspondence with Advance.

Finally, the out-of-court exchange between the parties continued until immediately before the hearing dates scheduled before the Board (September/October 2021). Exhibits ES-Kart 35c, 35d document further e-mail exchanges in 2021, which in particular included the last updated license offer (Exhibit ES-Kart 35) on March 25, 2021. In response to this offer, which differed from the prior offer by providing a lump sum offer for the back royalties, further discussions between Advance and XXX took place in April 2021. Even if the points of contention under discussion remained the same during the course of the negotiations, it cannot be said that the respective view was conclusive and irrevocable and that the license negotiations were therefore deadlocked. On the contrary, both Advance and XXX - albeit sometimes after repeated requests - finally responded to the requests of the other side and thus enabled the contract negotiations to progress. This is most recently evidenced by the final license agreement offer, which was based precisely on further product figures submitted by XXX.

**(2)**

Also other behaviors displayed by XXX do not (retroactively) invalidate the readiness for licensing. In detail:

**(a)**

Neither the raised parallel proceedings in Great Britain as well as the Netherlands of reverse rubric nor the (additionally) contained request for an anti-suit injunction lead to the fact that XXX could no longer be regarded as ready for licensing.

**(aa)**

The fact that proceedings under the reverse heading have been instituted in another jurisdiction does not have the general meaning that the Plaintiff, in case constellations such as the SEP user in the present case, is not prepared to accept the license.

As mentioned above, the ECJ has defined the maxim that if, in response to an infringement notice from an SEP holder, the potential patent user expresses a request for licensing to conclude a license agreement on FRAND terms, the license offer made by the patent holder must be responded to with diligence in accordance with accepted business practices in the field and in good faith, which implies that delaying tactics are not pursued (cf. ECJ, loc. cit., para. 65). The same applies according to the case law of the BGH FRAND-Einwand I or FRAND-Einwand II. According to these, the infringer must, after expressing his intention to license, subsequently participate in the licensing negotiations in a targeted manner and may not pursue delaying tactics. Both decisions make it clear that the mutual obligation to engage in a constructive exchange plays a central role. This means that both parties must cooperate in negotiations to conclude a license agreement and that neither side is entitled to torpedo the negotiations (see LG Düsseldorf, judgment of July 15, 2021, Case No. 4c O 73/20). This effect cannot be attributed without restriction to an action under a reverse heading. This is because the infringer must nevertheless be regarded as willing to accept a license, at least as long as it continues to participate purposefully in the discussions on the conclusion of a FRAND license agreement in the original infringement proceedings in which it raised the antitrust objection. Then the action brought does not manifest a blocking attitude of the SEP user towards the SEP holder and does not signal to the latter that there is no interest in licensing.

Accordingly, XXX did not torpedo the contract negotiations with Advance by filing suit in the UK. Rather, XXX continued the contract negotiations with Advance and with the individual licensors after January 2019. The Board is unable to establish that these talks were blocked. Insofar as the Plaintiff claims this, there is a lack of objective evidence from XXX's conduct that the focus of its efforts was exclusively on driving the court proceedings and that any negotiations vis-à-vis Advance took place only as

a sham. In the opinion of the Board, it is harmless if the conduct (in particular the submission of the counteroffer) was primarily intended to serve the proceedings conducted in the United Kingdom, because this may at the same time constitute a further pursuit of the license negotiations here. There is no reason to see why a procedural act should not at the same time have a positive effect for another context.

A delaying tactic of the ongoing license negotiations does not result from the filing of the lawsuit in Great Britain. It can remain undecided whether the lack of competence of the British jurisdiction was obvious and thus recognizable for XXX. What is supposed to be a delay of the contract negotiations here or even of the legal dispute here is neither presented nor evident. The Court of Appeal decided on March 26, 2021 and confirmed the judgment of the first instance (Annex ES-Kart 9), with which these proceedings are legally closed due to lack of jurisdiction.

It must also be taken into account that the SEP user suing under the reverse heading may have a legitimate interest in this action. Thus, the British proceedings would have had the counteroffer as their subject matter (standard) in terms of substantive law and should possibly have secured this. Based on the Huawei-ZTE criteria, this is not a question of license readiness (anymore), but a downstream question that the SEP user could have a legitimate interest in clarifying, especially if the offer is deemed to be contrary to FRAND and therefore no statement is made about the counteroffer anymore. The SEP user would have no clarity as to the legal validity of its counteroffer.

For the proceedings conducted since July 24, 2020 in the Netherlands with an extension of the claim under August 31, 2020 (GRÜ 11, 12\_1), the above statements apply accordingly.

**(bb)**

The above-mentioned foreign court proceedings are also not subject to a different rule insofar as the respective claims include an anti-suit injunction (for the UK, cf. p. 127 SdBI) and this could directly prove a user's unwillingness to license. The present legal

dispute does not provide any reason to subscribe to the opinion of LG München I cited below (cf. GRUR-RS 2021, 3995 - FRAND-Lizenzwilligkeit), which states:

"[...] If, however, such patent users are truly willing to be licensed, they will refrain from further unlawful interference with the proprietary legal positions of the patentees beyond the acts of use already committed and continuing. Or, to put it another way, a patent user who files an application for an ASI or threatens to do so cannot, as a rule, be considered sufficiently willing to grant a license within the meaning of the case law of the Court of Justice of the European Union and the Federal Court of Justice (cf. ECJ GRUR 2015, 764 - Huawei v. ZTE; BGH GRUR 2020, 961 - FRAND-Objection; judgment of 24.11.2020 - KRZ 35/17 - FRAND- Objection II; e.g. LG München I GRUR-RS 2020, 22577; 21 O 13026/19 at juris). Consequently, the patent user can also be required to declare not only his qualified willingness to license after receipt of the infringement notice, but also that he will not request an ASI."

Based on the relevant Huawei/ZTE criteria of the EU Court of Justice, neither the declaration of a qualified willingness to license nor the unprovoked statement of not wanting to apply for an ASI is required. Even if the procedure by means of an ASI (and subsequent AASIs, AAASIs, etc.) only became virulent within the last two years and therefore could not yet be taken into account by the ECJ decision, there is no reason in the present case to modify the requirements for readiness for licensing for this reason.

From the relationship between licensor and licensee, which is characterized by mutual cooperation in the conclusion of a license agreement without delay and without self-induced obstacles, it follows at most that the license seeker is obliged to declare whether he intends to apply for an ASI when asked specifically. The subsequent answer makes it clear to the patent proprietor how much the license seeker is actually interested in taking a license or whether he intends to delay or even torpedo to a considerable extent the constructive negotiations to be conducted in good faith.

These requirements are not met here. It is not apparent from the extensive correspondence submitted to the file that Advance made inquiries regarding the possible application for an ASI. In addition, such an ASI request in the constellation at issue must be treated within the provisions of the Brussels Regulation, which considers an ASI

inadmissible if/as such a decision would interfere with the jurisdiction of another Member State court. Thus, the SEP holder is already protected by this regulation and does not need any additional protection of its dominant position by denying the readiness to license to an SEP user due to the ASI request and the SEP holder could enforce its rights unhindered due to this.

**(b)**

From the negotiation history up to the conclusion of a bilateral NDA between the Plaintiff and XXX it is not clear that XXX has moved away from the willingness to conclude a license agreement.

In this respect, even the Plaintiff has expressed the fundamental opinion that it is already not usual to submit parallel license agreements during international license negotiations, but outside of legal proceedings (cf. p. 15 SdBI; ES-Kart 6). It seems at least contradictory if the Plaintiff invokes before the board that consequences to the disadvantage of XXX should result from this course of negotiations. Moreover, a refusal by a user to enter into an appropriate non-disclosure agreement only has an impact on the burden of presentation to be fulfilled by the SEP holder if it wishes to demonstrate the FRAND compliance of its offer. Because without such an agreement, these explanations may be less specific, information requiring secrecy may be anonymized or omitted altogether (cf. LG Düsseldorf, judgment of July 13, 2017, Case No. 4a O 154/15, beck-online, para. 322).

Nothing to the contrary is apparent from the specific timelines shown for the course of the NDA negotiations (see Annexes GRÜ 37, ES-Kart 34 et seq.; p. 130 Replica). The Plaintiff may admit that there were intervals in the correspondence of one to three months. However, this is not to the disadvantage of the Defendant. For, on the one hand, it must be taken into account that the entire communication since 2018 has not been characterized by a constant, swift exchange. On the other hand, the parties were in any case otherwise in communication during the "interruptions", so that only because

a point of discussion is temporarily not taken up, this does not prevent the Defendant's willingness to license. In any case, an NDA has been concluded between XXX and the Plaintiff in the meantime, so that the Plaintiff would now no longer be prevented from making a complete presentation and, in any case, the license negotiations were promoted by this - if it had been otherwise until then.

**(c)**

Even if the user's counter-offer were to be taken into account already at the level of the license request, this would at most be a further indication of XXX's willingness to license. Irrespective of whether the counter-offer complies with FRAND criteria in detail (see FRAND II, para. 102), it at any rate indicates a serious consideration of Advance's offer. Thus, there is no question between the parties that a lump sum payment as compensation for the past can in principle be agreed. As far as XXX has quantified this with USD XXX, this sum finds support in the sales information also provided by XXX. Irrespective of whether the information initially provided by e-mail dated October 19, 2020 (Exhibits GRÜ 21, GRÜ 22) was sufficient, Advance has in any case seen itself in a position to verify this amount after a further supplement from March 2021 (Exhibit ES-Kart 35, p. 347). A substantive evaluation of the result of this verification has to be omitted at the stage of the license request. What is decisive is that the payment offered is (has become) comprehensible. The same applies to the amount of the offered license fee. At the latest with the submission of the XXX expert opinion from mid-February 2021 (Exhibit GRÜ 70), XXX has also provided a well-founded justification approach here, whereby, as before, it is not a question of the license request whether the fee amount is FRAND-compliant. Therefore, the assessment of the counter-offer as not obviously un-FRAND is not precluded by the fact that the lump sum payment for the past offered on the part of Advance was set at USD XXX in the license offer from November 2021 (see p. 313 Duplica). For the question of the obvious FRAND infringement of the counter-offer is only to be considered whether it is coherent and comprehensible.

**1.3.**

The transmission of the standard license agreement in the version last updated in March 2021 (Annex ES-Kart 35) is to be regarded as a sufficiently concrete offer action

on the basis of the objective explanatory value. However, the content of the offer does not comply with the FRAND principles.

### **1.3.1.**

From a formal point of view, the license offer has been submitted in an effective and legally binding manner.

#### **(1)**

The license offer to be submitted by the patent owner must meet certain criteria in order to constitute a valid basis for license negotiations. It must be in writing and it must be sufficiently specific, which means that it must contain provisions on the license fee, its basis of calculation and the method of calculation. In addition, all those provisions must be included which are usually the subject of a license agreement (OLG Düsseldorf, loc. cit. - Mobiles Kommunikationssystem, para. 203 with further references). However, it is not a prerequisite that the offer is legally binding within the meaning of Section 145 of the German Civil Code (Bürgerliches Gesetzbuch - BGB) and can be accepted by a mere declaration of intent by the licensee. Consequently, it is not necessary that a signature of the licensor is already present (cf. LG Mannheim judgment of March 4, 2016 - 7 O 96/14, BeckRS 2016, 06527, beck-online).

In this context, the Düsseldorf case law requires that the SEP holder must explain the essential reasons on the basis of which it considers the remuneration parameters proposed by it to be FRAND. In other words, the patent proprietor must specifically explain why it believes that the remuneration parameters included in its offer (reference value, royalty rate) and the resulting royalty will lead to a user fee that is non-discriminatory and non-exploitative for the license seeker. This is necessary not least because the license seeker can only meaningfully discuss the license offer submitted to him with regard to its FRAND compliance if he is aware of the circumstances relating to the previous licensing practice. If he has already previously granted licenses to third parties, he must, depending on the circumstances of the individual case, provide more or less substantiated reasons in particular as to why the license remuneration he intends



to offer is FRAND precisely against this background (see OLG Düsseldorf, loc. cit. - Mobiles Kommunikationssystem; OLG Düsseldorf, GRUR-RS 2019, 6087, para. 241 - Improving Handovers).

If the license offer corresponds to a standard license program which is exclusively practiced in the contractual practice of the SEP Holder and accepted by third parties, it will regularly be sufficient to state and refer to the compliance of the license offer with the standard license agreement in order to enforce the license program. If, on the other hand, the SEP holder has concluded third party license agreements with different license terms, he will regularly have to present and explain at least the content of the essential license agreement terms of those agreements to a sufficiently reliable extent so that the license seeker can determine whether, if so to what extent, and for what factual reasons he is exposed to economically unequal terms (OLG Karlsruhe, GRUR 2020, 166 - Datenpaketverarbeitung).

If, at the time of the offer, there is no need for more concrete explanations of the method of calculation due to the individual circumstances of the case addressed, this may arise in the course of court proceedings, however, if individual material FRAND requirements are substantially disputed by the infringer, so that all calculation factors must now be specifically explained in any case (see OLG Düsseldorf, decision of November 17, 2016, I-15 U 66/15, para. 19, cited in juris; LG Düsseldorf, judgment of March 13, 2016, 4a O 126/14, para. 254). However, the specific further details must not contradict the original more general details, otherwise the offer is to be regarded as abusive in the absence of FRAND conditions.

## **(2)**

In the present case, the presentation of the method of calculation has been made in a sufficient manner.

It is not necessary at this point to clarify conclusively whether the approximately 200 license agreements concluded can be used as substantiated party submissions on the manner of calculation. Because in any case a license seeker like XXX receives

comprehensive information on the determination of the license fee at least via Advance's homepage and the white papers published there (cf. Exhibits ES 1e) and can understand how Advance has assessed and structured its fees. Since there is no requirement that the explanations of the basis of calculation be part of the license offer, there is no concern that they be provided separately on the website. As is known to the chamber, this is a common practice of patent pools, which regularly present their license program comprehensively on their website and provide background information. In this context, it is irrelevant whether the amount of the fees explained is actually reasonable. The more formal criterion of explaining the method of calculation is already sufficiently taken into account if the license seeker can at least understand the basis of calculation.

After that, the Defendant was able to understand how the royalties were generated. It had the white paper in its possession and was familiar with Advance's website. The Defendant did not criticize the comprehensibility of the content. The Defendant's criticism that the Plaintiff did not explain the license structure is to be distinguished from this. The Defendant cites this in connection with the comprehensibility of individual regulations and in order to be able to evaluate their content.

### **1.3.2**

Advance's license offer dated October 21, 2020, as updated on November 6, 2020 and March 25, 2021 (see Exhibit ES-Kart 14 et seq.; ES-Kart 35) does not satisfy FRAND principles.

It is, what the Defendant here exclusively claims, not fair and reasonable. The circumstance cited by the Defendant against the FRAND compliance of the license offer that a considerable number of already licensed patents are covered by the license offer and the compensation scheme provided for this is not fair and reasonable both after a merely summary examination of the FRAND offer in the sense of a negative evidence control (so LG Mannheim, WuW 2016, 86, para. 221) as well as after a factual

determination of the FRAND compliance of an offer, in which case there is at least a judicial margin of discretion (so OLG Düsseldorf, order of November 17, 2016, juris, para. 13; OLG Karlsruhe, order of May 31, 2016 - 6 U 55/16, juris, para. 30 - decoding device).

**(1)**

Fair and reasonable" contractual terms are those that are not offered to the licensee by exploiting a dominant market position. The contractual terms and conditions must be reasonable and must not be exploitative (OLG Düsseldorf, decision dated November 17, 2016, I-15 U 66/15, juris, para. 15). There is no abuse of a dominant market position if the SEP holder offers contractual terms and conditions that would also have been concluded without its dominant market position (Düsseldorf Regional Court, judgment of July 13, 2017, 4a O 154/15, juris, para. 305). Furthermore, an offer by the licensor may prove unfair/ unreasonable in particular if a license fee is demanded that significantly exceeds the hypothetical price that would have been formed in the event of effective competition on the dominant market, unless there is an economic justification for the pricing (LG Düsseldorf, judgment of March 31, 2016, 4a O 73/14, para. 225, cited in juris; Huttenlauch/ Lübbig, in: Loewenheim/Meessen/Riesenkampff/Kerstin/Meyer-Lindemann, Kartellrecht, Kommentar, 4th edition, 2020, Art. 102 TFEU, para. 182; Kühnen, loc. cit., Chapter E, para. 258). If the property right in question is a standard property right, unreasonableness may further result from the fact that, in the event of a license requirement, a cumulative total license burden would also result for the other standard property rights, which is not economically viable (Kühnen, loc. cit., Chapter E, para. 263). Similarly, market abuse may result from such contractual terms and conditions that affect the SEP user's primary performance obligations and are subject to the reasonableness test. If, precisely because of the market-dominant position, a contract has come into being with the condition in dispute which would not otherwise have been agreed in this way under normal market circumstances, this constitutes an abuse.

**(2)**

Measured against the principles described above, the offer presented in the standard license agreement is exploitative.

**(a)**

Thus, there are already considerable doubts as to freedom of exploitation if a license offer includes a not merely insignificant number of patents for which the license seeker already holds a license. For in this respect it must be taken into account that a license seeker is forced to pay license fees, for which there is no reason for legal and also other reasons, since a permission to use has already been granted to him by another license.

However, even if one considers an inclusion of patents in the license offer for which the license seeker is already licensed to be unavoidable under certain circumstances due to the given circumstances, the provisions provided by the Plaintiff or Advance for the compensation of double royalties already paid by the Defendant on the basis of license agreements concluded with other licensors or patent pools for partly the same patents are in any case not appropriate.

**(aa)**

The category of exploitative abuse is characterized by the pursuit of economic advantages by impairing the interests of trading partners and consumers. The standard of review is a potential state of effective competition; the ECJ focuses on whether a market dominator was able to obtain business advantages "which it would not have obtained under normal and sufficiently effective competition." To this end, he will often use his economic power resulting from market dominance as an instrument, although not by definition, because the most direct manifestation of monopolistic power is the simple exploitation of the dependence of market partners. The decisive aspect of this category of abuse is the harm to a contractual partner or to consumers. In this respect, disadvantages to trading partners or consumers without a simultaneous effect on the possibilities of action of competitors are the standard type of exploitative abuse. Such isolated harm to non-competing market participants results, on the one hand, from the imposition of unreasonable terms and conditions in vertical contractual relationships and, on the other hand, from arbitrary restrictions on performance (Grabitz/Hilf/Nettesheim/Jung, 73rd EL May 2021, TFEU, Art. 102, para. 166 et seq. ).

A dominant company therefore behaves exploitatively if contractual conditions are agreed which grossly disadvantage the contractual partner (cf. MüKo WettbR/Eilmansberger/Bien, 3rd ed. 2020, TFEU, Art. 102 para. 392). Just like excessive prices, other contractual terms and conditions can also unreasonably disadvantage trading partners and thus constitute a case of exploitative abuse. The exertion of additional pressure is irrelevant in this context. Only the economic superiority of the market dominator causes the coercion (Paschke/Berlit/Meyer/Kröner, Hamburger Kommentar Gesamtes Medienrecht, TFEU, Art. 102, beck-online, para. 26). This variant of abuse, which is formulated in Art. 102 p. 2 lit. a, covers all agreements between the contracting parties that influence the economic value of the business relationship. For the assessment of their inappropriateness, the same principles apply *mutatis mutandis* as for price abuse. In any case, obviously "unreasonable" contractual conditions (Grabitz/Hilf/Nettesheim/Jung, loc. cit., Art. 102, para. 175) or those according to which costs are obviously disproportionate to the service provided are unreasonable. As a rule, it is essential to weigh up the interests in each individual case. The principle of proportionality provides guidance. This principle not only prohibits a market dominator from pursuing a fundamentally legitimate business objective by unfair means, but also prohibits anything that restricts the contractual partner's economic freedom of action more than is necessary. In other words, there must be no means available that is milder for the contractual partner to achieve the purpose (Immenga/Mestmäcker/Fuchs, 6th ed. 2019, TFEU, Art. 102, para. 186). Therefore, a demand for the implementation of a contractual clause can be abusive if it goes beyond what the parties could reasonably expect from this contract (Grabitz/Hilf/Nettesheim/Jung, loc. cit., Art. 102, para. 175). In particular, unfairness does not cease to exist because the unreasonable prices or other terms and conditions are readily accepted by the trading partners (Paschke/Berlit/Meyer/Kröner, loc. cit., Art. 102, beck-online, para. 26).

**(bb)**

Irrespective of the question whether a pool license offer must generally provide for regulations which counteract the risk of double licensing, it can in any case be established in the present case that the Defendant already has a license for part of the patent contained in Advance's offer, so that the question of the necessity of an abstract regulation is not relevant in the present case. The Board has no doubt that the Respondent or XXX entered into a license agreement with MPEG LA in 2018, more precisely on December 12, 2018. The Respondent has already submitted with the Statement of Defence that it concluded a corresponding license agreement at the end of 2018. In the Plaintiff's reply of May 28, 2021, the Plaintiff did not dispute this fact, but merely made it clear on page 93 with a parenthetical addition "(by its own admission)" that, by its very nature, it had no knowledge of this. However, no doubts were expressed as to the correctness of the Defendant's original submission. Only in its written statement of September 7, 2021, on page 25, does the Plaintiff claim that the Defendant has not submitted any evidence of the conclusion of a corresponding license agreement and the payment of the license fees demanded therein, and submits that it maintains its denial with ignorance, which is ultimately irrelevant, however, since its offer also complies with FRAND principles if a corresponding license agreement has been concluded. The Respondent took this as an opportunity to clarify the conclusion of a license agreement with MPEG LA on page 34 of its pleading dated October 12, 2021, by submitting as Exhibit GRÜ 111 a confirmation from MPEG LA that XXX has been a licensee since the end of 2018. Furthermore, the first and last page of the license agreement (Exhibit GRÜ 112) was submitted and another confirmation from MPEG LA dated October 8, 2021 (Exhibit GRÜ 113). Insofar as the Plaintiff disputes the conclusion of a corresponding agreement with ignorance in its written statement of November 12, 2021, which was left open in this respect, this remains without success. The Plaintiff complains in this connection that the entire license agreement was not submitted, this is not convincing, since the MPEG LA as well as Advance license seekers provide a standard license agreement, so that it can be assumed that XXX has also concluded such a license agreement. The Plaintiff's objection that no proof of the fulfillment of the royalty obligation has been submitted does not help either, since the payment of royalties does not affect the internal relationship between licensor and licensee, but the

validity of a license agreement in the first place. Also the denial of an effective signature by XXX is without relevance. The power of representation of XXX has never been doubted by the Plaintiff in the negotiations over the years, so that it cannot be heard with this objection now.

The conclusion of a license agreement with MPEG LA has the consequence that XXX has a license at the time of the oral hearing which covers XXX% of those patents which are the subject of Advance's license offer, i.e. a not only insignificant number. It is not necessary to decide whether, for the assessment of the relevant intersection, only those patents are to be taken into account which specifically concern the licensee, and therefore those patents are not to be taken into account which are valid in regions (such as XXX and XXX in this case) in which the licensee is not active. It is true that the fact that on the licensing side it is also not set which property right is used in which area of validity and that regions which are not required are excluded from the license offer speaks against this differentiation. However, even according to the narrowest view advocated by the Plaintiff, an intersection of about XXX % remains in the present case according to the Plaintiff. This is still a size worthy of consideration, which makes a corresponding compensation regulation imperative.

**(cc)**

In the present case, it is also not necessary to conclusively clarify whether the accrual of double royalties for HEVC IP rights included in both the MPEG LA and the Advance Pool is exploitative with the view of the Defendant, if only because this situation would be comparable to that when an IP right is transferred to an acquirer and the acquirer is bound by the previous licensing practice (cf. OLG Düsseldorf, GRUR-RS 2019, 6098 - Improving Handovers). Even if a licensor is allowed to switch to the HEVC Advance Pool at issue on the basis of its competitive freedom and to charge different, namely higher, royalties compared to an established licensing practice, there is in any case no FRAND-compliant licensing practice in the present case with regard to the HEVC Advance standard license agreement to which a switching licensor could switch. Indeed, the contractual provisions of Advance's HEVC pool, which a dual licensor would offer

to a new licensee due to their character as a standard license agreement, do not meet the requirements of freedom from abuse.

**(dd)**

This is because a dominant company - mediated via a patent pool - may not blindly accept double licensing without having provided for a sufficient compensation mechanism in its contracts or in the accompanying ancillary agreements. It is true that not every unbalanced contractual clause is in principle suitable to constitute an abuse, because they are not all suitable to disadvantage the contracting party in the same way. This applies in particular to those contractual terms which do not regulate the main performance obligations of the parties, but predominantly relate to procedural issues and ancillary areas (jurisdiction clause, choice of law). However, since the handling of dual licensing at issue here concerns the main contractual performance obligations because it inevitably affects the amount of the license fee owed and is direct consideration for the granted use of the intellectual property rights, it is subject to the abuse test.

**(i)**

The dual licensee must therefore be provided with a binding regulation, i.e. one that already obliges the licensor unilaterally, on the basis of which he can see on which calculation basis and in which approximate amount he will receive a refund of royalties paid twice.

A licensee who is prepared to enter into a pool license via a technology standard can expect that a contractual provision will be offered which covers all issues relevant to the future contractual relationship. Therefore, a provision must be included in the license agreement which will come into effect in the event of dual licensing. This is because - as is generally agreed between the parties - property rights already licensed elsewhere must be taken into account in a license agreement at any rate if the overlap is not negligibly small (cf. Kühnen, loc. cit., Chapter E, para. 276). It is therefore in the intrinsic interest of a licensor who complies with antitrust law to include a



compensation provision in his agreement, at least as a precautionary measure, in order to be able to counter the case of double licensing. Apart from the notification and, if necessary, the proof of an existing double licensing, it must not be the task and sole matter of the individual licensee to approach each double licensing licensor in order to find a settlement with them regarding the compensation of double payments, while the license agreement as such has been concluded with a patent pool. This is because a pool licensor, which in principle wants to fulfill its FRAND obligations through a pool, thereby relieves itself of part of its antitrust obligations and passes them on to the licensee. It is then part of the licensee's sphere of risk whether he actually receives payment compensation for double royalties and enters into a further contractual relationship with a third party in return, which he is de facto urged to do by the pool because otherwise there would be no compensation at all in favor of the licensee.

**(ii)**

The dual licensing approach offered by Advance does not meet these requirements. Any reimbursement risk is passed on to the licensee.

Formal concerns are not yet subject to the fact that a compensation arrangement would not be contained in the same document as the actual licensing. This is because the contractual relationship between licensor and licensee may be set out in several independent documents or even orally, provided there is a factual connection between these several agreements (cf. Kühnen, loc. cit., Chapter E, para. 524).

Detached from a precautionary provision on double licensing, there is a concrete need for a compensation clause in the present case because there is a not insignificant overlap with the IP rights licensed via the MPEG LA HEVC pool in relation to the Advance Pool, which was explained at the beginning.

It is undisputed that Advance's standard license agreement itself does not contain any provision on double royalty payments. But even outside of this, there is no standardized and clear compensation mechanism that could supplement the license agreement in the sense of a side agreement. That this problem is nevertheless known to Advance is shown by the documents submitted on the duplicate royalty as well as XXX. On Advance's leaflet on the Duplicate Royalty Policy (Exhibit GRÜ 75), duplicate royalties are defined as follows:

"[...] duplicate Royalties are that portion of actual net royalty collections apportioned and distributed to all Licensors based on their respective patent portfolios [...]. "

For these, the three different refund options superimposed in the facts result. The types of reimbursement mentioned provide for:

- either a net distribution made by the licensor from the HEVC pool or
- receives from another pool/licensing program or
- based on a separate agreement between licensor and licensee.

This means for the licensee that at most a subsequent compensation payment will take place. Consideration of royalties already paid directly upon payment to Advance is not discussed at all. There is also no explanation as to how it comes to the selection of one or the other reimbursement method. XXX has already complained about this to Advance out of court (cf. Exhibit GRÜ 15, e-mail dated September 30, 2020) and considered it necessary as a consequence to approach the dual licensors themselves in order to find out the amount of a possible refund. A licensee has no information that and how he could reliably and bindingly understand which fee burden (or relief) will affect him before the conclusion of the contract. This is particularly evident in Step 2 of the implementation process (cf. Exhibit GRÜ 76), according to which the licensor is to decide on the type of reimbursement. There is a lack of any indication for the licensee on the basis of which objective criteria the choice of which billing method is to be expected.

Furthermore, it is clear from the information sheet GRÜ 75 that compensation for duplicate royalty payments will only be paid at all after either the licensee or the licensor

has become active, if he chooses to do so ("at licensor's election"). This is repeated in the document GRÜ76, which explains the "Duplicate Royalty Implementation Process" (cf. Step 1 in the screenshot shown in the facts). It requires an approach to the pool as well as a decision by the licensor that the pool administrator should control compensation payments via the licensee's payments. On its own, the pool does not take action to compensate for duplicate license payments.

The overall view of the standard license agreement with the pool agreement does not lead to a different understanding of the duplicate royalties problem described above. In the HEVC Agreement between the licensors and the license administrator, submitted as Exhibit ES-Kart 32, there is a clause in Section XXX which relates to the problem of duplicate licensing. It reads in part:

X  
X  
X  
X  
X  
X  
X  
X  
X  
X  
X  
X  
X  
X

According to this, the licensors are contractually required to compensate the licensee for any royalties paid twice. The three settlement methods listed are the same as those available on the pool's website. There are no criteria for how the licensor makes his decision.

This does not meet the requirements of an appropriate regulation for the licensee. There are no indications as to how the compensation by the licensors actually takes place. At best, this information could provide sufficiently well-founded information as to whether there is in fact a uniform approach and whether there is an established practice for refunds and whether it is thus foreseeable for a licensee which fee burden will affect him upon conclusion of a pool license agreement. However, even then it remains the case that an additional contractual agreement is required and the licensee must independently assert its - apparently undisputed - right to pro rata reimbursement of license fees paid twice. In this respect, there is a considerable risk of litigation should a licensor fail to conclude such an agreement or fail to pay.

It is also not sufficient that - as also referred to by the Defendant - item XXX of the XXX provides that individual patents can be removed from a specific license agreement according to the specifications of a licensor. Literally it says there:

X  
X  
X  
X  
X  
X  
X  
X  
X

This provision between Licensor and Advance is already not aimed at the cases of double licensing. By referring to the HEVC License ("in accordance with the terms of a HEVC License"), the XXX refers to Section XXX of the License Agreement, where the Licensed Patent is defined as follows:

X  
X

X  
X  
X  
X  
X

In Section XXX, in turn, there is in particular the provision that such patents may be excluded from the license on which a legal dispute is based. However, it is not apparent that individual patents may also be excluded from the license agreement for other reasons.

However, even if a license seeker could invoke this contractual clause and derive from it a claim to such exclusion - in the sense of a contract with protective effect in favor of third parties - and this clause did not only apply under the condition of item XXX of the standard license agreement (cf. Triplica, p. 24), action (which might be contentious in court) would again be required before the licensee would receive a refund of fees paid twice.

The proposed regulatory construct is therefore subject to criticism not only because of the uncertainty about the amount of compensation as such, but already because of the reference to a third party whose conduct is not bound to any concrete objective criteria. Therefore, the provision on compensation remains exploitative even if the fee amount specified in the third-party agreement would not be objectionable in itself. For an effective and appropriate clause for the reimbursement of double license fees, it is therefore not important at this point which calculation mechanism in detail leads to which concrete amount of compensation. For it is permissible that actual sales figures, depending on the sales territories, are only available after a certain accounting period and can only be subsequently included in a calculation at this point in time. However, the calculation formula as well as those parameters that can already be determined - including the percentage pool share of royalties collected attributable to a licensor - must already be named and identified beforehand. It must be clear to the licensee that this is not merely a pro forma provision, but an effective provision that purposefully counteracts systematic exploitation that would otherwise threaten (cf. Kühnen, loc. cit.,

Chapter E, para. 275). It is also possible and reasonable for a patent pool to indicate the rough calculation parameters. In particular, it has knowledge of how large a licensor's share in the pool is. This can at least be inferred from the Plaintiff's own submission. For example, when dealing with the bilateral counter-offers, the Plaintiff states that the license fees submitted are lower than the distribution that the Plaintiff receives from the pool licenses. However, the Plaintiff can only make this statement if it is aware of this amount, at least approximately. Further, in the Triplicate, the Plaintiff submits that Advance has a much larger portfolio than MPEG LA, so that each licensor receives a smaller percentage of the royalties paid by Advance. Again, this presupposes knowledge of the intra-pool split.

**(iii)**

The intended handling of dual licensing by the Plaintiff or Advance is not objectively justified and not in the interests of XXX. Neither concluded settlement license agreements nor other reasons lead to the appropriateness of this contract clause.

The conduct of a dominant company is not to be regarded as an exploitative abuse if it is objectively justified. In contrast to Article 101 (3) TFEU, the abuse provision in Article 102 TFEU does not contain an explicit statutory exemption. For some time now, however, efforts have been made to integrate an objective justification into the European prohibition of abuse by way of interpretation. In effect, this is nothing more than a form of "balancing of interests inherent in the facts", in the context of which legitimate economic reasons for the otherwise abusive conduct are sought within the characteristic of "abusive interpretation" (Immenga/Mestmäcker/Fuchs, loc. cit. , Art. 102, para. 152). In principle, abuse, detached from subjective reproachability and oriented to the principle of freedom of competition, conceptually necessarily includes a judgment of unworthiness in the sense of unreasonable or unjustified conduct. However, the market dominator must also be able to exploit its economic opportunities vis-à-vis the market opponent if there are special reasons and the weighing of the conflicting interests

shows that its conduct is objectively justified in order to protect overriding interests (MüKoEuWettbR/Wolf, 3rd ed. 2020, GWB, Section 19, para. 125).

**(α)**

License agreements can be used primarily to prove the reasonable nature of individual contractual terms. In principle, the more contracts that have been concluded, the easier it is to use them as an indication of the appropriateness of certain contractual provisions. This is because a sufficient number of license agreements can prove acceptance on the market and make further information on the reasonableness of a contractual clause unnecessary (LG Düsseldorf, judgment of July 13, 2017, 4a O 154/15, para. 311, cited in juris; LG Düsseldorf, judgment of July 11, 2018, 4c O 77/17, BeckRS 2018, 25099, para. 137). Accordingly, recourse to already concluded settlement license agreements benefits the licensor because, despite the burden of presentation incumbent on him, he is relieved of further factual submissions. However, a reference to parallel license agreements is not sufficient to prove the appropriateness of certain contractual clauses. Rather, the creation of the circumstantial effect requires that the contracts are identical in content (cf. OLG Karlsruhe, loc. cit., para. 123), which in particular relate to the same product market. This limitation to only certain concluded license agreements with relevant content is justified by the comparative market concept to be used for the question of exploitation abuse (cf. Kühnen, loc.cit., Chapter E, para. 415).

It is true that the passages from case law and literature cited above have so far referred primarily to the question of the reasonableness of royalties and not also to the reasonableness of other contractual provisions on principal performance obligations. No other standard is likely to be applied in assessing whether other contractual clauses are reasonable or exploitative, since both cases involve points at the same level of scrutiny, each of which may in itself constitute exploitative conduct on the part of the SEP holder. However, it does not have to be conclusively clarified here whether the derivation of appropriate contractual provisions can also be based on concluded settlement license agreements in the case of the issue of dual licensing. For in any case, an indicative effect cannot be established here. To the conviction of the court, it is not certain that

any settlement license agreements have been concluded with identical content, in particular with regard to a compensation provision for dual licensing.

**(β)**

Due to the requirement to refer at most to comparative license agreements from the same product market, it is justified to refer in a first step from the outset only to such comparative license agreements which relate to the product market XXX relevant here (cf. Kühnen, loc. cit., Chapter E, para. 524). In this respect, the Plaintiff admittedly states that the standard license agreement was also concluded on other product markets. However, it is not evident that these agreements on other product markets (e.g., cell phones) could provide information on the appropriateness of certain contractual provisions for clearly distinguishable and not mutually interchangeable products such as TV/set-top boxes. The mere regulation of identical license fees does not justify this approach. Nor is it sufficient for this purpose to make a general forecast that a licensee could be active on this market in the future. For although the standard license agreement, due to its comprehensive character, does not impose any restrictions with regard to the licensed products and the sales territories, in the case of an individual licensee only his current field of activity is always decisive in order to determine comparable companies. A future business area can only be included if, for example, there are already sufficiently concrete indications for an expansion of the product portfolio (see LG Düsseldorf, judgment of July 11, 2020, 4c O 44/18). According to this, there exist here around 30 license agreements for the relevant product market of XXX manufacturers, which Advance has concluded with other XXX manufacturers.

With regard to the license agreements remaining thereafter, whereby in this respect a license agreement could also form the relevant standard (cf. Kühnen, loc. cit., Chapter E, para. 534), in a second step the recognizing court must be convinced that they are identical in content, since only then do they have an indicative effect. In order to trigger the indicative effect, it is necessary, even without the submission of the agreements, for the licensor to submit a statement that their regulatory content does not differ. Such a statement is all the more necessary if - as is the case here - it is known that, in addition to the conclusion of the standard license agreement, side letters, i.e. ancillary



agreements, have been concluded. These in turn have a direct effect on the subject matter of the agreement and significantly change the exchange ratio of performance and consideration in relation to competitors of the licensee. In this way, a standard license agreement can be individually tailored and modified with regard to the specific situation of a licensee. In the course of the proceedings, however, the Plaintiff did not provide any further details on the (usual) regulatory content of these side letters. In addition, it is not only the side letters that are relevant here, but all the more so the third-party agreements. The extent to which and the content with which such agreements with the approximately dual licensees have been concluded to date has not been explained.

However, even with such a presentation of the contractual content, the license agreements concluded in the present case could not have indicated the appropriateness of the disputed regulation of the dual licensing cases. This is because the third-party agreements would retain their character as bilateral arrangements with a contractual partner other than the actual licensor itself if they were at least included as an annex in the side letters and were thus known to the pool. It is not apparent that the pool or the other licensors who have joined together in the pool could influence their content. It is solely the individual dual licensors who enter into the agreements with the dual licensees. By officially providing as a third regulatory option in the duplicate royalty policies that licensee and licensor are free to determine the compensation, Advance emphasizes on the one hand the independent negotiating position of the dual licensors and on the other hand the independence of this agreement from Advance. This is all the more contrary to the justification of an indicative effect, especially since common objective criteria are not provided for the third regulatory variant.

This makes it all the less necessary to clarify whether, of the 30 XXX producers, it would actually only be the XXX company that would be comparable to XXX as a licensee - even after its entry into the HEVC Advance Pool as a licensor.

Contrary to the opinion of the Plaintiff, the Board does not deviate from previous case law with this legal assessment. It does not follow from the above that any settlement license agreements to be submitted should be dealt with differently. The Board does not even have conclusive factual evidence that all standard license agreements were

concluded with identical contents. There is a total lack of explanations regarding existing side letters and - known to the court - agreements between dual licensors and licensees, even though the Defendant pointed out in its reply that it was not aware of these circumstances. It would also have been necessary to explain how many of the dual licensees already had other license agreements prior to the conclusion of the agreement with Advance and nevertheless accepted the disputed dual licensing arrangement. On the basis of the general procedural rules of presentation alone, the Plaintiff would have been required to make a precautionary and exemplary presentation on this topic, completely detached from the presentation of individual settlement licenses. There was sufficient opportunity to do so both in the triplicate and in the oral proceedings. The submission of the license agreements could not have replaced this argument.

**(v)**

The Board is also unable to identify any other objective justification for the compensation mechanism at issue.

In addition to settlement agreements that are to be given priority, the Plaintiff is in principle free to present other facts in a substantiated manner that justify the compensation mechanism provided for by the pool. However, the explanations given by Advance as to why it is not possible for it to have a different compensation arrangement are not convincing.

In principle, it is to be expected from a pool licensing that it is a complete and conclusive agreement. This applies both to licensors who are themselves affected by the issue of dual licensing and to those who license their patent only via the Advance Pool, but where the conclusion of a pool license nevertheless results in dual licensing for the licensee. Here, too, the idea of simplifying pool licensing applies and that the standard agreement must be drafted so broadly that it takes into account all case scenarios, regardless of how many licensors would be affected. The reference to partly bilateral agreements with dual licensors is therefore an intolerable attempt to evade the antitrust obligations of a pool licensor.

Within the framework of the factual justification, it is not necessary to conclusively examine whether this method of regulation is unobjectionable because there is actually no legal possibility for the Advance Pool, for example on the basis of the Commission's Technology Transfer Guidelines (Guidelines on the Application of Article 101 TFEU to Technology Transfer Agreements, [2014/C 89/03]), to keep the pool free of dual licensors or at least not to make intellectual property rights that overlap with another license agreement the subject matter of the agreement. For it is the licensors themselves who control the legal scope of action of a patent pool and thus can also influence which IP rights are to become the subject matter of a licensing. However, the fact that such scope for action was not granted to the pool may not be used as an objective justification. The question of whether uses are to be permitted exclusively via a patent pool or also by way of bilateral licenses is detached from this.

The Plaintiff's argument that it does not want to provide for an approach to dual licenses until the licensee has proven the fulfillment of its contractual obligations vis-à-vis the other licensor does not constitute sufficient justification. It is admitted that the Plaintiff/Advance has no knowledge of whether the contractual conditions vis-à-vis the other contractual partner (here MPEG LA) are fulfilled and whether a license is then granted in this relationship (cf. p. 99 SdBI - clause from the license agreement with MPEG according to which the granting of the sublicense is dependent on the fulfillment of certain conditions). However, this is not relevant for the occurrence of a repayment obligation. Sufficient trigger for a regulation is the existence of another regulation at all and the question whether the licensee formally has an obligation to pay. Whether the licensee complies with this obligation in detail, on the other hand, only concerns the relationship between the contracting parties and is not suitable for limiting the scope of application of the compensation mechanism.

It is further to be recalled against the offered dual licensing provision that it is at most subsequently eliminated by the third party agreements, i.e. at a point in time after the licensee has already entered into the license agreement and thus entered into the obligation to pay royalties also of already licensed patent. The dual licensee is thus forced

to accept the license offer as pre-formulated, without the inadequacy being eliminated and without even knowing how the compensation would be structured. It is completely unknown how and when the concrete agreements with the licensors and the licensee will be reached.

The lack of a provision on dual licensing is also not justified by the fact that there will no longer be a need for such a provision due to the mere passage of time. This is because the problem of double licensing payments is not rendered obsolete simply by the fact that more and more licensors of HEVC SEP patents are switching from MPEG LA to Advance. It is true that in the specific relationship of the current pool licensing, there could be less and less overlap over time. Nevertheless, there is also a third HEVC pool (XXX), of which it is not at all known how large switching ambitions of the individual licensors are or will develop. Moreover, no forecast can be made as to whether a new pool for the HEVC standard will not be formed in the future. Particularly since there are (as the Plaintiff specifically assumes in the triplica, p. 21) regularly several pools which overlap in terms of content. This alone shows that the provision of such a compensation clause has ongoing practical relevance. Moreover, and this is decisive for the present legal dispute, there is in any case a need for regulation on dual licensing as long as at least the switch between MPEG LA and HEVC pools can be carried out.

Nor does the fact that the license fees remain constant and are not adjusted, i.e. increased, despite the addition of new property rights serve as an objective justification for the Plaintiff. This does not constitute adequate compensation for double license fees paid. It may be favorable for a licensee if constant fees are charged in a patent pool despite growing patent portfolios. However, this is a favorable circumstance that affects all licensees, not dual licensees in particular. Without a separate compensation scheme for duplicate royalty payments, the dual licensee benefits at best from the

overall decrease in royalty burden. This does not make a regulation of dual licensing cases obsolete. The resulting abuse of exploitation must be treated appropriately in its own right.

The Plaintiff also does not cite any compensation method other than retrospective compensation as to how duplicate license payments could be countered in a factually appropriate manner. To this end, it refers several times in general terms to the possibility of "pre-netting", which is understood to mean already reduced license payments to the pool without the need for subsequent compensation. However, apart from its mention in out-of-court correspondence (cf. GRÜ 27: e-mail of November 3, 2020 from Advance to XXX), there are no further indications that this could be a serious alternative besides the reimbursement mechanism under the Duplicate Royalty Politics.

The compensation scheme provided for by the MPEG LA Pool together with the repayment mechanism (Annex GRÜ 26) cannot be a justification for the selected dual licensing scheme in the Advance Pool either. This is because here, too, there is no knowledge of the actual implementation of the compensation scheme provided for in the MPEG LA Pool.

Nor is the Plaintiff's further argument about how other patent pools deal with double licensing convincing. It does not provide any plausible factual justification for the regulation envisaged here. Even assuming the Plaintiff's submission on other patent pools to be correct - which is why it is not necessary to decide whether it could be taken into account according to the rules on lateness - the Board is unable to infer from it any compensation regulation for cases of double licensing that is customary in the industry. Thus, an overlap of different pools only exists with respect to the respective HEVC patent portfolios of Advance and MPEG LA, respectively, and for both pools the practical handling of dual licensing cases is not known. For MPEG LA's AVC pool, no duplication is apparent. With regard to XXX and XXX and their UMTS/LTE patents, licensing via the XXX pool only occurs for the automotive sector. Due to the consumer electronics sector, which is treated separately and licensed independently, there is

regularly no duplicate licensing here. This is underlined by the example of the initially existing bilateral XXX license cited by the Plaintiff in its written statement. By agreeing to terminate the bilateral license relationship, the Defendant and XXX have made it clear that they want to avoid patent overlaps in different agreements.

#### **1.4.**

Nor can it be established in favor of the Plaintiff that the pool's license offer satisfies FRAND principles if the offer were to be understood as including only those standard-essential patents for which a license has not already been concluded. This was addressed by the Plaintiff for the first time in the oral proceedings. However, no further circumstances were presented on the basis of which the conclusion could be drawn that the requested license fee is fair and reasonable if - assuming the Plaintiff's argument - XXX% of the patents were not included in the offer. A fortiori, it cannot be assessed whether this would also apply if XXX % of the patents had been excluded from the scope of the license.

#### **1.5.**

The pool's license offer, which contradicts FRAND principles, is also attributable to the Plaintiff regardless of the fact that it is not itself one of the dual licensors.

This is because, as the XXX (Exhibit ES-Kart 32) between the Plaintiff and Advance as the Pool Administrator discloses, the latter is intended to act precisely for the Plaintiff as the patent owner. Plaintiff is using the Pool Administrator for the very purpose of fulfilling its antitrust obligations to SEP users. By having recourse to the pool administrator, the Plaintiff simplifies the fulfillment of its obligations in its favor and saves itself from having to contact license seekers specifically. This is a recognized procedure in the context of license negotiations, as can also be seen from the above, without any negotiating party doubting that the pool administrator acts with effect for the respective SEP holder (see LG Düsseldorf, judgment of January 08, 2019, Case No. 4c O 12/17).

The Plaintiff has not shown why a different consideration should be required in the present case. Above all, it has not exculpated itself by, for example, providing Advance with specific contractual terms, which Advance would have arbitrarily disregarded. On the basis of the licensing via the patent pool, it is rather to be assumed that the conditions once established with all licensors or at least subsequently approved were to be applied unchanged by the pool administrator in all future cases. It is not evident that a licensor is also involved in the pool license negotiations.

#### **1.6.**

Whether the new pool offer of November 10, 2021 (Exhibit ES-Kart 58) submitted in the pleading of November 12, 2021 satisfies FRAND principles is not for the Board to decide. This is because this offer, including the associated factual submissions, must be rejected as being out of time pursuant to Section 296a of the German Code of Civil Procedure (cf. Kühnen, *loc. cit.*, para. 435).

According to this rule of civil procedure, after the conclusion of the oral proceedings, upon which the judgment is rendered, pleas in law and defenses may no longer be raised. The purpose of this rule is to enable the court to reach a decision without being disturbed by the submission of further procedural material on which the opposing party could no longer comment. § Section 296a of the Code of Civil Procedure is an expression of the applicable duty to promote proceedings, i.e., the obligation to present arguments in a timely manner and with sufficient content (MüKoZPO/Prütting, 6th ed. 2020, ZPO, Section 296a para. 1; Greger in: Zöller, *Zivilprozessordnung*, 34th ed. 2022, § 296a ZPO, para. 1). The only exceptions to this general exclusion are pleadings that have been admitted by the court at the request of the party, for example pursuant to Section 283 of the Code of Civil Procedure. In this case, there is an opportunity to reply to the extent that it was no longer possible to respond to the opponent's submissions before or during the oral proceedings. The granting of the relief does not give the party the opportunity to make a further comprehensive submission on all the aspects in dispute.

Based on this principle, the pleading relief - in accordance with the Plaintiff's request - was limited exclusively to new factual submissions in the Defendant's quadruplica. There, the Defendant did not allege any factual circumstances which would have been new for the Plaintiff and therefore would have been a reason to submit an amended pool offer. Moreover, the Plaintiff itself does not claim that the new offer was submitted on the basis of the submissions contained in the quadruplicate. It must be conceded to the Plaintiff that the court informed it for the first time during the oral proceedings of those aspects on the basis of which FRAND-compliant conduct could not be established. This corresponds to the usual judicial procedure, of which the Plaintiff is also aware. The Plaintiff was given extensive opportunity to comment on this. A separate reference to the problem of dual licensing on the part of the Board, on the other hand, was unnecessary because the parties had already been exchanging views on this issue both before the court and in court since the end of 2018. Moreover, as is known to the courts, this issue also exists vis-à-vis other license seekers. Accordingly, it was only a logical consequence that a discussion of this discussion point would take place in the oral proceedings. In this respect, it is not clear why it should not have been possible for the Plaintiff to submit an updated offer prior to the oral proceedings which takes into account the concerns about double licensing.

### **1.7.**

Nor is the intervener able to assert its objection and demonstrate abusive and discriminatory conduct on the part of the Plaintiff. Even if the Plaintiff has established its licenses in such a way that they are only granted at the level of terminal equipment manufacturers, and not to chip manufacturers such as the intervener, the intervener is not placed at a disadvantage as a result. The licensing of other levels in the exploitation chain necessarily presupposes that there is a potential licensee at a different level than the end device manufacturer (cf. Kühnen, loc. cit., Chapter E, para. 490 with reference to the licensing request). The intervener, as a chip manufacturer, is in principle to be assigned to a different level of exploitation. However, it is not evident that it would have shown (serious) interest in such a license vis-à-vis the Plaintiff/advance. Without such



a declaration of willingness to license, a licensor is not required to deviate from its previous licensing practice.

### 3.

Finally, the Plaintiff is not helped in enforcing its claims by recourse to the bilateral relationship with the Defendant, for which the bilateral offer and counteroffer submitted would have to be taken into account.

The Plaintiff is bound by its licensing practice - via the pool - under antitrust law and cannot deviate from its practice without providing explicit objective reasons. In the present case, it can be left open whether the fact that an offer by a patent pool is in violation of antitrust law does not in itself preclude an objective reason, since the reference to the bilateral offer, which is merely discussed "in passing", could be an attempt to circumvent the binding of the individual patentee to the pool in order to preclude an infringement of antitrust law.

It cannot be established that there are objective reasons on the part of the Plaintiff for concluding a bilateral license.

### 1.1

In principle, a patent proprietor who complies with obligations under antitrust law can be expected to also offer potential licensees the conclusion of bilateral licenses (cf. LG Düsseldorf judgment of December 12, 2018 - 4b O 4/17, BeckRS 2018, 37930, para. 293), which has the direct consequence that contract negotiations are opened at both levels. A license seeker is therefore basically at liberty to explore the terms of the license in parallel with both the pool administrator and a patent proprietor. Granting the parties a right of choice in this respect does not violate antitrust law (cf. LG Düsseldorf, loc. cit., para. 294).

If, however, the licensing practice of a patent proprietor is geared to one form of licensing, in this case a pool license, the licensor's right to choose is limited to this one practice. The contractual restriction of the freedom of choice to the customary practice finds

its justification in the fact that the actual custom of the industry has developed towards the granting of pool licenses. In this respect, it is generally recognized in case law that an established industry practice is a suitable argument for the FRAND compliance of certain contractual provisions.

However, the restriction of the right of choice to the current practice does not completely exclude the possibility of offering a licensing practice other than the one practiced so far. In such cases, if a patent proprietor requests a deviation from the previously practiced equal treatment of all licensees, he must present compelling, objectively comprehensible reasons for this. Only then could it be justified under FRAND aspects to deviate from the practice practiced so far.

Factual reasons for requesting an individual license may be, for example, that the license seeker only makes use of the standard essential property rights of this one patent holder or that the license seeker, if he uses further SEPs, also intends to take individual licenses from the other SEP holders.

## **1.2**

Measured against these criteria, the Plaintiff has not succeeded in presenting an objective justification for an individual license. In this context, the Plaintiff has admittedly always referred the Defendant to the conclusion of a bilateral license due to the expressed criticism of Advance's license offer. However, no comprehensible facts, let alone an objective reason for the conclusion of a bilateral license agreement, were presented.

The course of negotiations also gives no indication of such a factual reason. Even the negotiation period of a few months, which was allotted to bilateral talks, was significantly shorter than the talks held with the pool over several years. The parties placed the focus of the negotiations on pool licensing, to which the bilateral talks were subordinate or in the shadow of which they proceeded. With respect to the bilateral offer,

there was an exchange of views between the parties over a period of eight months, which the Board is not convinced took place in earnest due to the sometimes longer intervals in the correspondence. Rather, the parties soon agreed that a pool solution was preferable. XXX then continued his discussions with Advance, to which the Plaintiff offered no resistance. This shows that it is neither in the interest of the Plaintiff to enter into a bilateral contractual obligation nor are there any other objective reasons why the Plaintiff as licensor could deviate from the previous licensing practice.

#### **4.**

In addition to what has already been said, the Defendant's written statement, which was left open, did not give rise to the reopening of the oral proceedings pursuant to Section 156 of the Code of Civil Procedure with regard to those points which go beyond the admitted reply. Pursuant to Paragraph 1 of this provision, which is the only provision to be considered here, the court may order the reopening of a hearing that was closed. The discretionary decision to be made by the court is based on the relevance of the continuation of the proceedings.

#### **1.1.**

The further license offer of November 10, 2021 was made after the conclusion of the oral proceedings and thus too late. For no procedural reason can this offer be taken into account in the present legal dispute. In particular, it is not necessary from a procedural economic point of view to reopen the proceedings so that the parties could negotiate the updated contractual terms in this context and the Plaintiff does not have to take legal action again, based on the new offer. As explained, the purpose of the provision of § 296a ZPO is precisely to give expression to the conclusion of the oral proceedings and to provide the court with a conclusive factual basis on which a decision can be rendered. Without this formal limitation of the subject matter of the proceedings, this is not possible and a speedy decision-making process would no longer

be guaranteed. In the present case, there is all the less reason to reopen the case, since the infringement action is only dismissed as "currently" unfounded if the antitrust objection is successful, which directly implies the possibility of further action. The Plaintiff is not cut off from any possibility of legal protection.

## **1.2.**

Furthermore, the other arguments put forward by the Plaintiff (p. 50 of the post-hearing brief) do not call for reopening on the basis of judicial discretion.

The submission of license agreements was not decisive for the dispute and the Board does not assess their non-production as a departure from its previous case law to the detriment of the Plaintiff. In any case, the Plaintiff already had sufficient opportunity up to the oral proceedings to submit a possible request for production and, in particular, to substantiate that in this way information could be gained about agreements with dual licensors. Since the question of the Defendant's willingness to license was not relevant for the treatment of the bilateral offer, there is likewise no departure from established case law here.

The preliminary legal assessment of the subject matter of the dispute did not have to prompt the Board to issue a notice to the Plaintiff, either before or during the oral proceedings, together with the possibility of improving the pool license offer. This is because the judicial duty to point out has its limits. The parties must be given the opportunity to discuss the factual and legal situation with the court. This alone enables the parties to recognize which aspects are likely to be relevant for the decision. Information by the court is particularly appropriate in cases where, despite careful conduct of the proceedings, it was not foreseeable for the parties on the basis of which considerations the court would reach a decision (cf. Kühnen, loc. cit., Chapter E, para. 436). This was the case here. Just as stated in connection with the new license offer, the parties were aware from the beginning of their contractual negotiations that the handling of dual licensing would become a decisive aspect requiring regulation. It was therefore obvious that the court would make an assessment in this regard, and a positive or negative assessment would at best entail a general litigation risk.

**1.3.**

Finally, nothing else follows from the further mutual, non-released pleadings of the parties. The opposing party already has no right to reply again to a subsequently submitted pleading pursuant to § 296a ZPO without being requested to do so (cf. Zöller, loc. cit., § 283, para. 6). All the less is the party who has been granted leave to file a further reply entitled to do so. Such responses disregard the rules of civil procedure on the conclusion of oral proceedings. The provision of Section 296a of the Code of Civil Procedure does not give the parties extensive opportunities to make up for previously omitted submissions. In any event, the pleadings do not contain any relevant new factual arguments that would have required the Board to reopen the proceedings.

**IV.****1.**

The Plaintiff is entitled to a claim for damages against the Defendant on the merits pursuant to Art. 64(1) EPC in conjunction with Sec. 139(2) Patent Act to the extent tenorized.

**1.1**

As a specialist company, it would have been incumbent on the Defendant to check whether the products offered and supplied infringed the patent in suit. By failing to carry out a corresponding check, the Defendant disregarded the due care required in the course of trade, Sec. 276 (2) BGB.

**1.2**

The liability for damages can also be determined here without prejudice to whether the claim for damages is limited in amount to a FRAND-compliant license fee because the Defendant fulfilled the requirements incumbent on it with regard to the FRAND procedure established by the ECJ.

The claim for damages on the merits merely requires the probability of some kind of damage (OLG Düsseldorf, GRUR-RS 2019, 6087, para. 227 - Improving Handovers).

Such a claim exists in the present case even if - which would be the subject of an examination in possible amount proceedings - the claim for damages is to be limited to the payment of a FRAND-compliant license fee (*loc.cit.*).

### 1.3

The Plaintiff also has the necessary legal interest in the requested determination within the meaning of Section 256 (1) of the German Code of Civil Procedure. The occurrence of damage on the part of the Plaintiff is sufficiently probable. It is not possible for it to quantify this damage because it is unaware of the information through no fault of its own.

### 2.

The claim for information under Art. 64(1) EPC in conjunction with Sec. 140b Patent Act (request No. I. 3.) remains unaffected by the objection to compulsory licensing under antitrust law successfully raised here (also OLG Düsseldorf, *ibid.*, para. 28). This is because such an objection merely presupposes an unlawful act of use within the meaning of Sections 9 - 13 Patent Act. Such an act is present here. Facts which make the provision of information appear disproportionate within the meaning of Sec. 140b (4) Patent Act have not been presented.

### 3.

Insofar as the Plaintiff requests an accounting, it is only entitled to this claim to the extent recognizable from the operative part pursuant to Art. 64, para. 1 EPC in conjunction with Secs. 242, 259 German Civil Code, so that it is enabled to quantify the claim for damages to which it is entitled. The Plaintiff is dependent on the tenorized information, which it does not have through no fault of its own. The Defendant is also not placed under a recognizably unreasonable burden by the information it is required to provide.

In the present case, the claim for information under Sections 242, 259 German Civil Code does not include any information on costs and profits of the Defendant in connection with the patent infringement due to the successfully raised objection of compulsory licensing under antitrust law. If the SEP holder can only demand an appropriate license fee corresponding to FRAND conditions for the use of the patent-compliant teaching, the principle of good faith dictates that the obligation to provide information

and render accounts should also be limited to the information required to calculate this FRAND license fee (OLG Düsseldorf, *ibid.*, para. 230 - Improving Handovers; a. A. LG Mannheim, GRUR 2018, 864, para.110 - Funkstation).

According to the now established case law of the Düsseldorf Chambers (see LG Düsseldorf, judgment of September 21, 2017, Case No. 4a O 18/16, para. 224, cited in *juris*; Kühnen, *loc. cit.*, Chapter D., para. 826), the Plaintiff can - at its option - only demand information and invoicing also in electronic form, i.e. in addition to the form generally owed in writing, insofar as the corresponding documents are also already available electronically at the Defendant. Consequently, the Plaintiff has no right to demand that the Defendant convert the documents it holds into electronic form.

## **V.**

In view of the objections raised by the Defendant against the patent in suit, a stay of the legal proceedings pursuant to Section 148 of the German Code of Civil Procedure (ZPO) was not required until a decision had been made in the nullity proceedings, even at first instance.

### **1.**

According to the opinion of the Boards (Mitt. 1988, 91 - Nickel-Chromium Alloy, BIPMZ 1995, 121 - Hepatitis C Virus), which was confirmed by the Düsseldorf Upper District Court (GRUR 1979, 188 - Flachdachabläufe; Mitt. 1997, 257, 258 - Steinknacker) and the Federal Court of Justice (GRUR 1987, 284 - Transportfahrzeug; GRUR 2014, 1237 et seq. – Kurznachrichten), an opposition to the patent in suit or the filing of the nullity action as such do not yet constitute a reason to stay the infringement litigation, since this would in fact amount to attributing to the attack on the patent in suit an effect inhibiting patent protection that is alien to the law (Sec. 58 (1) Patent Act). Instead, the interests of the parties must be weighed against each other.

If the patent in suit is challenged with an opposition or with a patent nullity action, the infringement court, if it affirms an infringement of the patent in force, generally only sentences for patent infringement if it does not consider a declaration of nullity to be

(sufficiently) probable; otherwise it must suspend the hearing of the legal dispute pursuant to Section 148 of the German Code of Civil Procedure (ZPO) until a decision has been made on the nullity action at least in the first instance (BGH, GRUR 2014 1238 - Kurznachrichten). This is because an - provisionally enforceable - obligation of the Defendant to cease and desist, to provide information, to render accounts, to recall as well as to destroy products in compliance with the patent cannot be justified as a rule if it is to be expected with sufficient probability that this order will be deprived of its basis by the declaration of invalidity of the patent in suit. The claim to the safeguarding of justice, which follows from the principle of the rule of law (Art. 20 (3) GG) in conjunction with the fundamental rights and is thus constitutionally guaranteed, requires that the infringement Defendant be provided with effective legal protection if he wishes to defend himself against the attack from the patent in suit with a counterattack on the legal existence of this patent. This requires not only an effective possibility to conduct this attack itself by filing an action for a declaration of invalidity or by filing an opposition, but also an appropriate consideration of the fact that this attack may also be a - and possibly the only - means of defense against the claim arising from the patent. Due to the legal regulation, which for the claims according to Sec. 139 et seq. Patent Act, the attack against the patent in suit cannot, unlike in other legal systems, be conducted as an objection in infringement proceedings or by filing a counterclaim for a declaration of nullity. However, this must not result in denying this attack any effect on the infringement proceedings. Suspension of the infringement dispute is rather required in principle, but also only if it can be expected with sufficient probability that the patent in suit will not withstand the opposition filed/the pending nullity action (BGH, GRUR 2014 1238 - Kurznachrichten). This cannot be assumed as a rule if the invalidity attack is directed to questioning the novelty or the inventive step in finding the teaching according to the patent in suit, but reasonable arguments can still be found for an affirmation of patentability, which also depends in this respect on the evaluative assessment of the instances responsible for this. The same applies in cases in which the prior art cited



in opposition to the patent in suit has already been taken into account in the granting proceedings or the patent in suit has been maintained in the first instance (cf. Kühnen, loc. cit., Chapter E., para. 815f.).

## **2.**

The Board was unable to determine the decisive success of the action for annulment with the necessary degree of probability.

### **2.1.**

A novelty-damaging anticipation of the teaching according to the patent in suit by the version of the HEVC standard published on December 18, 2012 in the form of Working Draft 9 (submitted as Exhibit B 5, submitted in German (partial) translation as Exhibit B 5'; hereinafter: B 5) could not be established.

#### **2.1.1.**

Novelty-damaging is present if the citation objectively discloses the prior art; incorrect assumptions or determinations of the Plaintiff in the patent specification itself are irrelevant (BGH GRUR 1999, 914, 917 - Kontaktfederblock). The assessment of whether the subject matter of a patent is affected by a prior publication in a manner detrimental to novelty requires the determination of the overall content of the prior publication. Decisive is which technical information is disclosed to the person skilled in the art. The concept of disclosure is not different from the one used in patent law (BGH GRUR 2009, 382, 384 - Olanzapin; GRUR 2004, 407, 411 - Fahrzeugleitsystem). Therefore, it is not to be determined in which form the person skilled in the art, for example, can implement a given general teaching with the help of his technical knowledge or how he can possibly modify this teaching, but exclusively what the person skilled in the art "directly and unambiguously" takes from the prior publication as the content of the (general) teaching given by it (GRUR 2002, 146, 148 - Luftverteiler; GRUR 2004, 133, 135 - Elektronische Funktionseinheit; GRUR 2008, 597, 598 - Betonstraßenfertiger; GRUR 2011, 999, 1001 - Memantin; BGH GRUR 2021, 1043, 1044 - Cerdioxid; OLG Düsseldorf, judgment of 19 February 2016, Ref. I-2 U 55/15, para. 50, cited after juris).

#### **2.1.2.**

The board was unable to find that there was a lack of effective claiming of the two priorities of the US prior applications US 2012/61624098 P (submitted as Exhibit B 6; hereinafter: B 6) and US 2012/61666185 P (submitted as Exhibit B 7; hereinafter: B 7) by the patent in suit.

According to Art. 87(1) EPC, the effective claiming of priority requires, *inter alia*, that the subject-matter of the subsequent application is identical to the subject-matter of the prior application ("the same invention"). The prior and subsequent applications only contain the same invention within the meaning of Art. 87 EPC if the relevant disclosure is identical (cf. BGH GRUR 2004, 133, 135 - Elektronische Funktionseinheit). The content of the priority document is determined by the entirety of the application documents and not only by the content of the claims therein. The principles of the examination correspond in this respect to those of the examination of novelty, whereby a claim to priority of the earlier application cannot be considered if the subsequent application is to be regarded as new compared to the previous application (Moufang/Schulte, *loc. cit.*; Sec. 41 PatG/Art. 87-89 EPC, para. 33 *et seq.*). However, identity in the sense of priority law does not mean a literal correspondence but a factual congruence, whereby it is decisive that the inventive idea is the same in both applications (cf. Moufang/Schulte, *loc. cit.*, para. 35 with reference to BGH GHRUR 2002, 146 *et seq.* - Luftverteiler). In this case, differences in the subject matter of the subsequent application do not prevent the claiming of priority, provided that a person skilled in the art can readily recognize the common inventive concept when comparing the two applications (see BGH GRUR 2009, 390, 392 - Lagerregal).

It is undisputed between the parties that both B 6 and B 7 reproduce the wording of claim 1 on pages 26 (B 6) and 70f. (B 7) are largely identical in wording. However, it is equally undisputed that the priority documents do not comprise the embodiment example of Figure 27 of the patent in suit and that it is therefore not mentioned in the description passages of paragraphs [0152] *et seq.* in particular paragraph [0154], which introduces the term slice segment in the patent in suit. The skilled person, however, finds sufficient indications in the priority documents - despite the absence of the

aforementioned embodiment example - that a breakthrough of the boundaries of slice segments is also disclosed in the priority documents. For example, it finds such an explicit reference in the third paragraph of the abstract of B 6. There it is stated: "*Therefore, a new encapsulation format for WPP substreams [2] is proposed, a dependent slice. This dependent slice may contain Entropy Slice data, a WPP substream, a full row of LCUs, just a fragment of a slice, where the prior transmitted slice header also applies to the contained fragment data*". The B 6 thus already discloses in the introductory part of its description that it not only refers to slices as a unit, but also recognizes smaller units in the form of parts of a slice ("fragment of a slice"). These parts of a slice are the (un)dependent slice segments of the patent in suit.

### **2.1.3.**

Since the patent in suit has validly claimed priorities, it is no longer relevant whether the B 5 directly and unambiguously discloses all features of the asserted claims, especially since the Plaintiffs have not countered the Defendant's corresponding submission on the merits.

## **VI.**

The admissible counterclaim is well-founded.

The counterclaim for damages asserted by the Defendant is based on Sections 33 (1), 33a GWB in conjunction with Art. 102 TFEU. Art. 102 TFEU.

### **1.**

The prerequisite for a claim is that on the one hand there is a user who is willing to license, but on the other hand the SEP holder refuses to conclude a license agreement or submits an offer that does not comply with the FRAND criteria. The claimant must then be placed in the position he would have been in without the antitrust infringement (cf. FRAND I para. 111; Kühnen, loc. cit., Chapter E, para. 318).

### **2.**

These factual requirements are met.

**2.1.**

The Plaintiff has the right to bring an action. Contrary to the Plaintiff's view, the claim is not directed against Advance; the claim is directed only against the Plaintiff. The extent to which it is also responsible for Advance's conduct is rather a question of attribution. For this purpose, Advance does not have to be sued specifically, nor does it have to hold a dominant position specifically, etc. (see lit. aa)).

**2.2.**

As stated in the reasons for the decision, the Defendant or XXX as its XXX parent company has shown itself to be sufficiently and continuously willing to grant a license. To avoid repetitions, reference is made to the above explanations.

**2.3.**

For the evaluation of the pool license offer, reference can also be made to the previous presentations. Since, in the Board's view, the treatment of dual licensing is abusive, the pool license offer does not meet the FRAND criteria. Since the relevant pool offer was made by Advance, it is justified to include its conduct in the Plaintiff's failure to comply with FRAND conduct obligations and to attribute it to the Plaintiff. In this respect, reference can be made to the statements under section 1.5.

The wording of the license agreement also confirms this understanding and supports the attribution of Advance's conduct to the Plaintiff. For there it states in the introduction under the heading "Recitals" in the 7th paragraph:

"Whereas, Licensing Administrator desires to grant a HEVC Advance Patent Portfolio License (as defined below) under the fair, reasonable and non-discriminatory terms and conditions set forth in this Agreement;"

Regardless of whether the pool administrator is actually bound by the antitrust requirements, as shown there in the clause, this clause nevertheless shows the understanding

of the licensors and the pool administrator: they act in an effort to meet their legal obligations. These are also known to the pool administrator.

The question of whether a license seeker is in a better procedural position if he only asserts a claim for the submission of a FRAND offer instead of a claim for the conclusion of a FRAND license agreement does not need to be clarified in the present case with regard to the claim for the determination of an obligation to pay damages. Irrespective of the fact that the non-FRAND conformity of the offer results from the above statements of the Board, the Defendant does not directly request the conclusion of the contract, but only attaches consequences to it. These arise in an identical manner in the case of non-fulfillment of the claim to submit a FRAND offer.

#### **2.4.**

On the legal consequences side, the Plaintiff is obliged to pay damages. The Defendant's damage to be liquidated consists in being required to pay more than a FRAND license fee for the use of the patent in suit that would have been payable in the event of lawful conduct by the patent proprietor (namely full damages), which is why its claim for in rem restitution is to indemnify it against such claims for damages that exceed a FRAND license fee (see OLG Düsseldorf, GRUR-RS 2019, 6087, beck-online, para. 227 - Improving Handovers).

#### **C.**

The subsidiary decisions follow from sections 92 and 709 of the Code of Civil Procedure.

A separate determination of the amount in dispute for the counterclaim was not necessary due to Sec. 45 (1) Sentence 3 GKG.

XXX

XXX

XXX